



**record C 127 X**

User manual

## **Document identification**

Article nr.: 121-006454632  
Version: 1.3  
Publication date: 02/05/2023

Translation of the original manual

Subject to technical modifications  
Copyright © agtatec ag

# Table of contents

<b>Table of revisions</b> .....	<b>5</b>
<b>1 Safety</b> .....	<b>6</b>
1.1 Presentation of warning signs .....	6
1.2 Intended purpose of use .....	6
1.3 General hazards.....	7
1.4 State of technology .....	9
1.5 Personal protective equipment.....	9
1.6 Spare parts and liability.....	10
<b>2 General information</b> .....	<b>11</b>
2.1 Purpose and use of the instructions.....	11
2.2 Copyright.....	11
2.3 Product identification.....	11
2.4 Manufacturer agtatec ag .....	11
2.5 Target groups.....	11
2.6 Definition of terms .....	12
2.7 Abbreviations .....	12
<b>3 Description</b> .....	<b>14</b>
3.1 Construction .....	14
3.2 Types .....	15
3.3 Wind load brake .....	16
3.4 Lever arm .....	16
3.5 Sliding arm (optional) .....	16
3.6 BDE-D.....	16
3.7 Components.....	17
3.8 Functional description .....	17
3.9 Functional description Inverse .....	17
3.10 Low energy drive.....	18
3.11 Primary / secondary application .....	18
3.11.1 Functions .....	18
<b>4 Technical data</b> .....	<b>19</b>
<b>5 Operation</b> .....	<b>20</b>
5.1 Control panel BDE-D.....	20
5.1.1 Operation modes and button functions .....	20
5.1.2 Perform reset .....	21
5.1.3 Display system information .....	22
5.2 Parameter overview .....	22
5.3 Configuration C 127 X.....	23
5.4 Configuration FEM V1_10 with STG127 V2_40_E .....	24
5.5 Description of parameters.....	25
<b>6 Inspection and maintenance</b> .....	<b>26</b>
6.1 General remarks .....	26
6.2 Door care .....	27
6.3 Maintenance and regular inspection .....	27
6.4 Logbook .....	27
6.4.1 General information .....	28
6.4.2 Operator duties .....	28
6.4.3 Commissioned technician .....	29
6.4.4 Legal principle.....	30
6.4.5 Extent of the inspection.....	30

## Table of contents

---

6.4.6	Requirements for documentation .....	30
<b>7</b>	<b>Malfunctions .....</b>	<b>31</b>
7.1	Status displays .....	31
7.2	Troubleshooting .....	32
<b>8</b>	<b>Taking out of service and disposal .....</b>	<b>33</b>
8.1	Decommissioning.....	33
8.2	Dismantling and disposal .....	33

## Table of revisions

<b>D</b>	
<hr/>	
Description of parameters	
Parameterc changed .....	25
<b>P</b>	
<hr/>	
Parameter overview	
New Parameter list .....	22

# 1 Safety

## 1 Safety

### 1.1 Presentation of warning signs

Various symbols are used in this guide for easier understanding:



#### NOTICE

Useful advice and information to ensure correct and efficient workflow of the system.



#### IMPORTANT

Specific details which are essential for trouble-free operation of the system.



#### IMPORTANT

Important details which must be read for proper function of the system.



#### CAUTION

Against a potential hazardous situation that can lead to minor personal injury and property damage.



#### WARNING

Against a latent hazardous situation that can lead to severe injuries or death and cause substantial property damage.



#### DANGER

Against an imminent hazardous situation that can lead to severe injury or death.



#### DANGER

Against an imminent or latent hazardous situation that could lead to electric shock and cause serious injury or death.

### 1.2 Intended purpose of use

The system is designed exclusively for use as a pedestrian passage. The installation must only occur in dry areas. If there are deviations then proper waterproofing and water drains will be required on site.

Any other application or use beyond this purpose is not considered to be an intended purpose. The manufacturer bears no liability for any resulting damage; the operator alone shall bear the associated risk.

The intended purpose also includes observation of the operating conditions specified by the manufacturer, in addition to regular care, maintenance and repair.

Interventions in or alterations to the installation performed by non-authorized maintenance technicians exclude the manufacturer's liability for consequential damages.



#### NOTICE

The operation of an automatic door in combination with a wicket door may only take place if the latter is in a secured position.

## 1.3 General hazards

The following section lists hazards that can be caused by the system even when used as intended. To reduce the risk of malfunction, damage to property or injury to persons and to avoid dangerous situations, the safety instructions listed here must be observed.

The specific safety instructions in the other sections of this manual must also be observed.



### IMPORTANT

**The country-specific regulations must be observed and complied with!**



### WARNING

**Serious injuries and major property damage.**

Incorrect mounting can lead to serious injuries and/or cause major damage to property.

- a) Observe and comply with all important instructions regarding safe assembly.



### IMPORTANT

**To avoid malfunctions, moving objects such as flags or parts of plants must not be allowed to enter the detection range of the sensors.**



### NOTICE

**The installation must be inspected during the function and safety check for imbalance and signs of wear or damage to cables, springs and fastening parts.**

**The equipment must NOT be used if repair or adjustment work needs to be carried out.**



### NOTICE

**Checking, repairs, service, maintenance and cleaning may only be carried out when the system is at a standstill and switched off. Before work can be started, persons must be barred from the system and the danger area.**



### CAUTION

**Risk of malfunctions, material damage or injury due to improper settings!**

- a) Improper settings can lead to malfunctions, material damage or personal injury.
  - ⇒ Do not disconnect the system from the power supply overnight.
  - ⇒ Settings should only be made by personnel qualified to do so.
  - ⇒ Do not disassemble, put out of operation or manipulate safety devices.
  - ⇒ Have faults rectified by specialist personnel or by personnel qualified to do so.
  - ⇒ Have service and maintenance carried out according to locally applicable regulations or according to a maintenance contract.



## CAUTION

**Risk of malfunctions, material damage or injuries due to insufficient or missing cleaning or care!**

- a) Insufficient or inattentive cleaning or care of the system can lead to malfunctions, damage to property or injury to persons.
  - ⇒ Check the sensors regularly for dirt and clean them if necessary.
  - ⇒ Regularly remove dirt accumulations in the floor rail or under the floor mat.
  - ⇒ Keep the system free from snow and ice.
  - ⇒ Do not use aggressive or caustic cleaning agents.
  - ⇒ Use road salt or loose chippings only conditionally.
  - ⇒ Lay the floor mat without folds and flush with the floor.
  - ⇒ Equipment required for cleaning purposes such as ladders or similar must not be leaned on or attached to the system.



## CAUTION

**Risk of material damage or injury due to unforeseen opening, closing or turning of the door!**

- a) The door can open, close or turn unexpectedly. This may result in damage to property or injury to persons.
  - ⇒ No persons may be present in the opening area of the system.
  - ⇒ Ensure that moving objects such as flags or parts of plants do not enter the detection range of the sensors.
  - ⇒ Do not make any settings on the control unit when the system is in use.
  - ⇒ Have faults rectified immediately by specialist or personnel qualified to do so.
  - ⇒ Remove objects from the opening area.
  - ⇒ Do not disassemble, put out of operation or manipulate safety devices.
  - ⇒ Do not rush through a closing system.



## CAUTION

**Risk of bruising and severing of limbs!**

- a) If the system moves, careless behaviour can lead to serious injuries to limbs or severance of limbs.
  - ⇒ Do not reach in when parts of the system are moving.
  - ⇒ Keep a distance when parts of the system move.
  - ⇒ Do not bump into or touch the system when it is moving.
  - ⇒ Do not open or remove protective covers during operation.
  - ⇒ Do not permanently remove covers from the system.
  - ⇒ Only carry out inspection, service, maintenance and cleaning when the system is stationary and switched off.



## CAUTION

**Danger of material damage or injury due to non-functioning safety devices!**

- a) If safety devices are not functioning, manipulated or put out of operation, there is a risk of damage to property or injuries that can lead to death.
  - ⇒ Never disable or manipulate safety devices.
  - ⇒ Have inspection, service and maintenance of the safety devices carried out according to local regulations or according to a maintenance contract.





## CAUTION

**Danger of malfunctions, damage to property or risk of injury if used by unauthorised persons!**

- a) If unauthorised persons use the system, there is a risk of malfunction, damage to property or injury to persons.
  - ⇒ Children under 8 years of age may only use the system under supervision.
  - ⇒ Children must not play, clean or maintain the system.
  - ⇒ Persons with limited physical, sensory or mental abilities as well as persons with insufficient knowledge or experience may only use the system under supervision or must have received and understood instructions to do so.



## DANGER

**Danger to life due to electric current!**

- a) In case of contact with live parts, there is an immediate danger to life due to electric shock. Damage to or removal of the insulation or individual components can be life-threatening.
  - ⇒ Before starting work (cleaning, maintenance, replacement) on active parts of electrical systems and equipment, ensure that all poles are voltage free and that this is maintained for the duration of the work.
  - ⇒ Keep moisture away from live parts. This can lead to a short circuit.
  - ⇒ Never bridge fuses or put them out of operation.
  - ⇒ Do not connect the power supply until all work has been completed.
  - ⇒ Have work on the electrical system performed by qualified personnel only.



## DANGER

**Danger to life due to non-functioning safety devices of the fire protection system!**

- a) If safety devices of the fire protection system do not function properly, there is a risk of serious or fatal injuries.
  - ⇒ Never disconnect the fire protection system from the power supply overnight.
  - ⇒ Do not disassemble, put out of operation or manipulate safety devices.
  - ⇒ Do not remove safety instructions on the system.
  - ⇒ Never block, hold open or otherwise prevent fire doors from closing.
  - ⇒ Have inspection, service and maintenance of the fire protection system carried out in accordance with locally applicable regulations or according to a maintenance contract.
  - ⇒ Have the fire protection system checked and maintained according to the state of the art.

## 1.4 State of technology

This system was developed using state of the art technology and officially recognized technical safety regulations. The system, depending on its options and diameter, comply with the requirements of the Machine Guidelines 2006/42/EG as well as EN 16005 and DIN 18650 (D).

Nevertheless, danger may arise if not used as intended.



## IMPORTANT

**Installation, commissioning, inspection, maintenance and repair work may only be conducted by qualified, trained and authorized technicians.**

**After commissioning or repair work, fill in the check list and give it to the customer for safe keeping.**

**We recommend obtaining a service agreement.**

## 1.5 Personal protective equipment

Personal protective equipment is used to protect persons from adverse effects on health. Personnel must wear personal protective equipment during the various work activities on and with the system.

Personal protective equipment is explained below:



Hearing protection is used to protect the hearing from noise. As a rule of thumb, hearing protection is compulsory from when normal conversation with other people is no longer possible.



The head protection serves to protect against falling and flying parts and materials. It also protects the head from bumping into hard objects.



Protective goggles protect the eyes from flying parts, dust, splinters or splashes.



Protective gloves are designed to protect hands from friction, abrasions, punctures or serious injury and from burning caused by contacting hot surfaces.



Safety shoes protect the feet from crushing, falling parts and slipping on surfaces. The puncture resistance of the shoes ensures, that pointy objects do not penetrate the foot.



The high-visibility vest is used to make the personnel stand out and therefore to be seen. With improved visibility and attention, the high-visibility vest protects personnel in busy work areas from collisions with vehicles.

Depending on the place of work and the working environment, the protective equipment varies and must be adapted accordingly. In addition to protective equipment for specific work, the work site may require other protective equipment ( for example a harness).

In hygiene-protected areas, special or additional requirements of personal protective equipment may be required. These requirements must be considered when choosing personal protective equipment. If there is any uncertainty regarding the choice of personal protective equipment, the safety officer must be consulted at the place of work.

## 1.6 Spare parts and liability

Reliable and trouble free operation of the door is only guaranteed when using parts that were recommended by the manufacturer. The manufacturer declines any liability for damages resulting from unauthorized modifications to the door or the use of parts that are not permitted.

## 2 General information

### 2.1 Purpose and use of the instructions

These instructions are an integral part of the system and enable efficient and safe handling of the system. In order to ensure proper functioning, the instructions must be accessible at all times and kept in the immediate area of the system.

Although only the male form has been chosen for reasons of better legibility, the information refers to members of both sexes.

The operator must have read and understood the manual before starting any work. The basic requirement for safe working is to follow the safety instructions and the handling instructions. In addition, the local regulations and safety rules apply.

The manual can be handed over in extracts to instructed personnel who are familiar with the operation of the system.

The illustrations are for basic understanding and may differ from the actual presentation. Specific representations are contained in the drawings.



#### IMPORTANT

A replacement of the instructions is available from the supplier or on the website.

### 2.2 Copyright

The copyright for these instructions remains with:

agtatec ag

The instructions may not be reproduced, distributed, or used for the purpose of competition without the written consent of agtatec ag.

Infringements shall result in the obligation to pay damages.

### 2.3 Product identification

The nameplate located on the door provides accurate identification of the product.

### 2.4 Manufacturer agtatec ag

#### **agtatec ag**

Allmendstrasse 24

CH – 8320 Fehraltorf

Switzerland

Phone: +41 44 954 91 91

### 2.5 Target groups



#### CAUTION

##### **Risk of injury if personnel are insufficiently qualified!**

If unqualified personnel work on the system or are in the danger zone of the system, dangers may arise which can cause serious injuries and considerable damage to property.

- a) All work must be carried out by qualified personnel only.
- b) Keep unqualified personnel away from danger areas.

This operating manual is intended for the target groups listed below:

- Operating entity of the system:  
the person who is responsible for the technical maintenance of this system
- Operator of the system:  
the person who operates the system every day and has been suitably instructed

## 2 General information

### 2.6 Definition of terms

Term:	Explanation:
System	The term is also used in these instructions as a synonym for the product. Door operators, revolving doors, sliding doors, etc. are referred to as a system. If information in these instructions refers to a specific type, this is shown accordingly in the text.
User	Users are all persons who use the system.
System operator	The respective owner is referred to as the system operator, regardless of whether they operate the system as the owner or pass it on to third parties.
Authorized representative	The authorized representative takes over certain parts of the manufacturer's obligations with regard to fulfilling the requirements of the Machinery Directive. In particular, the authorized representative may also place the system on the market and/or sign EC declarations of incorporation.
Qualified personnel	Qualified personnel are authorized and appropriately trained to perform the following work: – Disassembly, Assembly, Commissioning, Operation, Audit, Maintenance, Troubleshooting, Decommissioning The qualified personnel have several years of professional experience in the technical field, e.g. as mechanics or machine fitters. The qualified personnel are aware of the residual risks arising from the installation site and, due to their professional training, knowledge and experience, are able to carry out the work assigned to them and to independently identify and avoid possible danger points.
Manufacturer	The manufacturer is whoever designs and/or builds machinery or incomplete machinery under the scope of the Machinery Directive.
Life phases	All phases of the system's condition and use are referred to as life phases. This applies from the time the system leaves the factory until it is disposed of.
Personnel	All persons who carry out activities on and with the system are referred to as personnel. Personnel can be, for example, the operator, the cleaning staff, or the security staff. The personnel meet the personnel qualifications required by the manufacturer.
Service technician	Experts and specialists or representative authorized by the manufacturer to perform commissioning, maintenance and servicing.

### 2.7 Abbreviations

Abbreviation	Description
ABS	Absolute pulse generator
AKA	Actuating-contact „outside“
AKG	Actuating-contact „common“
AKI	Actuating-contact „inside“
ASK	Terminals inside header
ATE	Drive unit
BDE-D	Electronic control unit
BDI	Control unit (rocker switch)
BDI-M	Circuit board for mechanical control unit
BKL	Control unit LED
BODYG	Sensor „Bodyguard“
CAN-H	Serial data interface
CAN-L	Serial data interface

Abbreviation	Description
CPU	Central processing unit
DFA	Automatic swing door operator
EEPROM	Program memory
ES	Electrical circuit diagram
FV	Manufacturing regulation
GTR	Gearing
HS	Main switch 2-pole
IKG	Encoder
KA	Cable exit
LED	Light Emitting Diode
LD	Light Emitting Diode
LS	Cable plan
MF	Multifunctional switch
MOT	Motor
MP	Principal assembly diagram
NA	Emergency stop
NET	Power supply unit
NS	Main power switch
NSA	Mains failure
RAD	Radar, Motion sensor
RAILB	Light barrier „Railbeam“
SI	Fuse
SIO	Safety open
SIS	Safety close
SSK	Key operated contact
STG	Control unit
STP	Control pc board
SURV	Time switch „Locked“
TOE	Door locking
TOW	Door opening width
TOZ	Door open time delay
μP	Mikroprocessor
VAK	Locking contact
VL	Wiring list
VMA	Instructions for wiring and assembly
VRR	Locking

### 3 Description

### 3 Description

#### 3.1 Construction

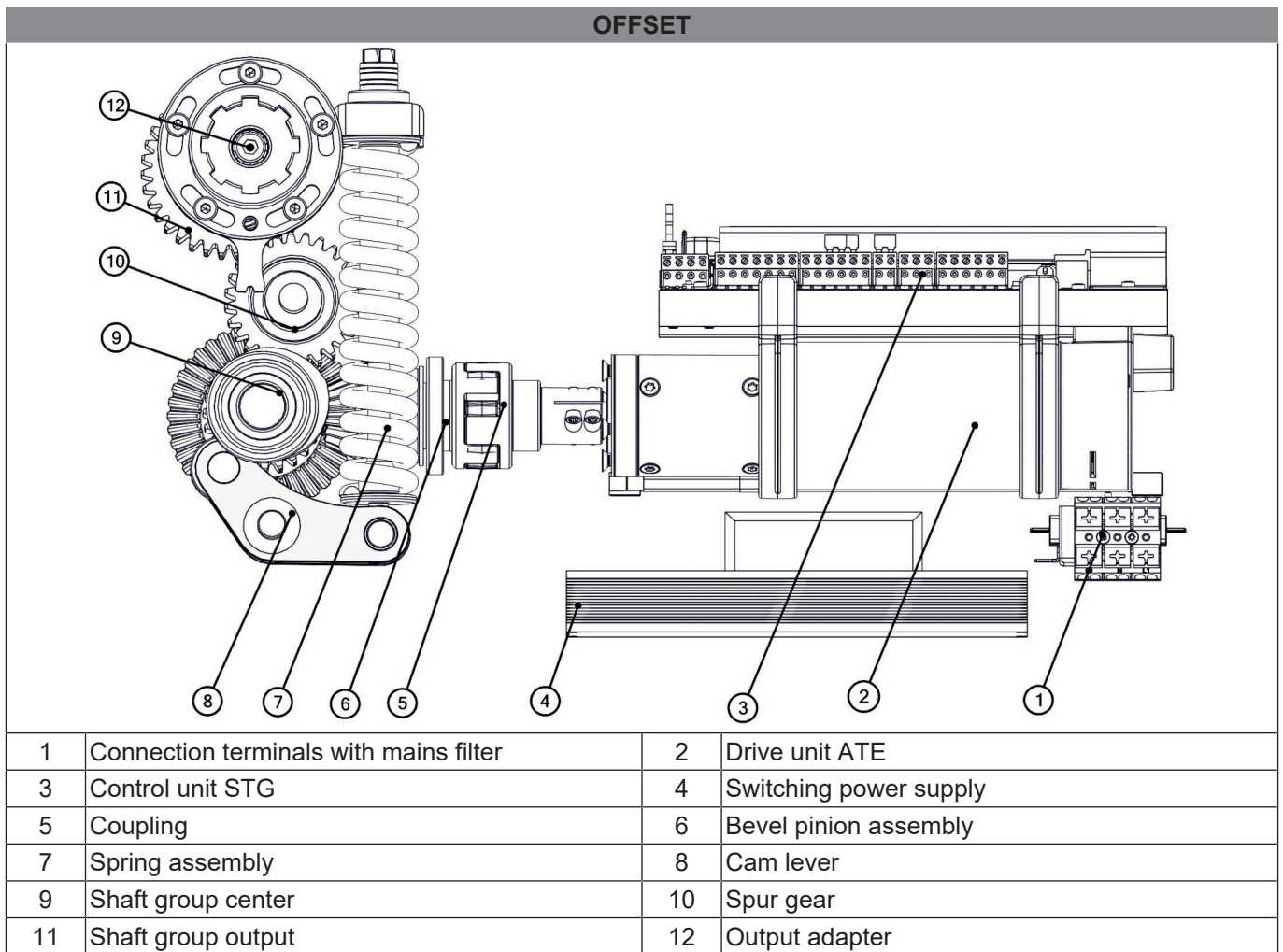
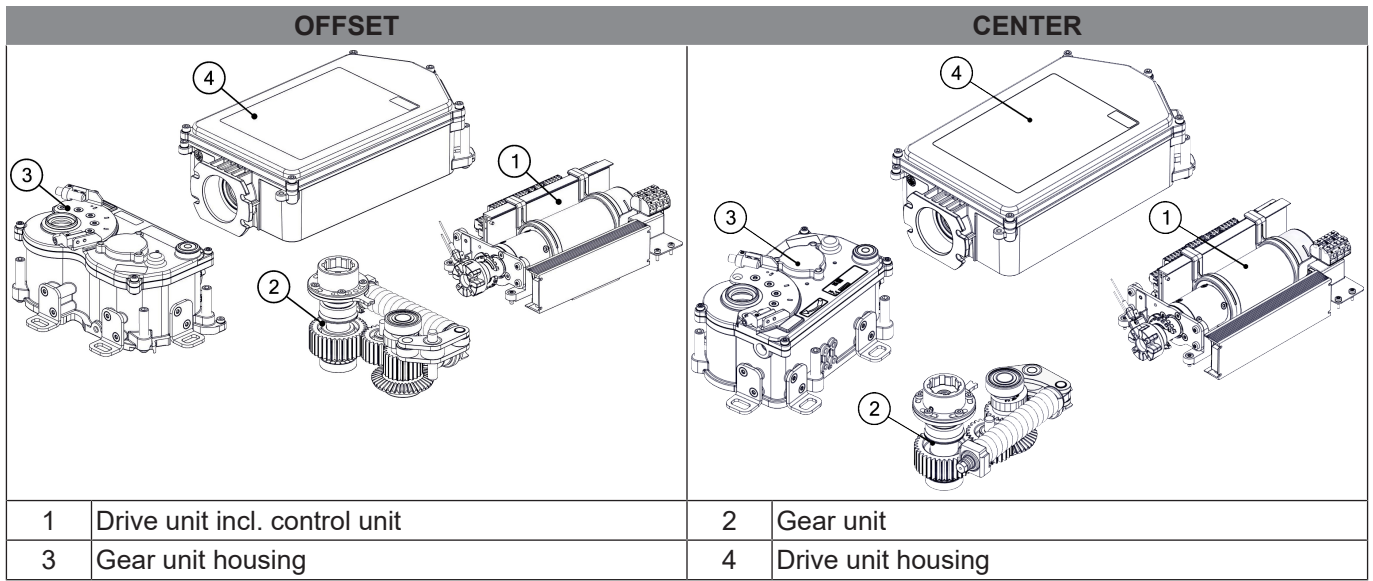

CENTER

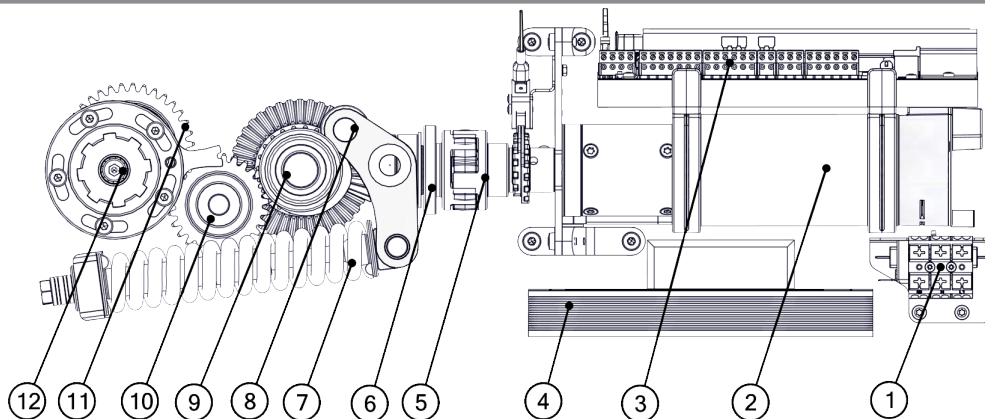

1	Connection terminals with mains filter	2	Drive unit ATE
3	Control unit STG	4	Switching power supply
5	Coupling	6	Bevel pinion assembly
7	Spring assembly	8	Cam lever
9	Shaft group center	10	Spur gear
11	Shaft group output	12	Output adapter

3.2 Types

C 127 X OFFSET CCW-1	C 127 X OFFSET CW-1
C 127 X OFFSET CW-2	C 127 X OFFSET CCW-2
C 127 X CENTER CCW	C 127 X CENTER CW

### 3 Description

#### 3.3 Wind load brake

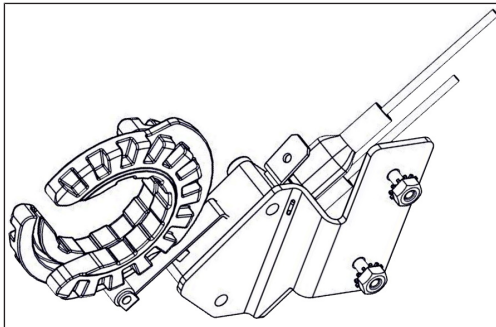

Wind or manual slamming can damage the drive and/or door leaf. The wind load brake reduces the negative effects of the door leaves slamming shut or opening.

The wind load brake only functions when the drive is disconnected from the power supply system.

The installation must be carried out by qualified personnel.

#### 3.4 Lever arm

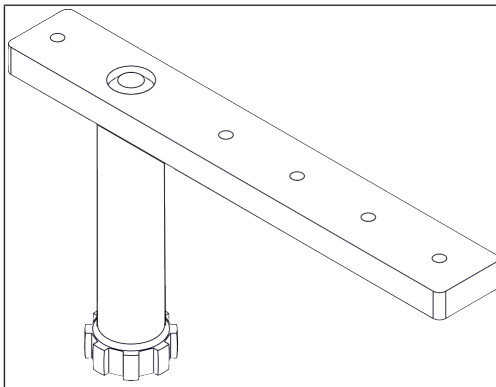

The lever arm is custom made.

- With direct connection and power transmission between output shaft and door leaf.
- The lever arm can be installed in the door leaf or base profile of the door leaf.
- A suitable counter bearing for the door leaf must be provided.

#### 3.5 Sliding arm (optional)

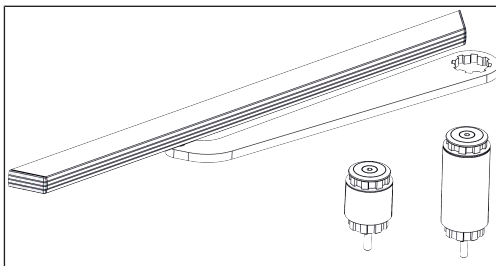

The sliding arm is suitable for support in pulling and pushing applications.

- The Sliding arm can be installed in the door leaf or base profile of the door leaf.
- An adjustable mechanical stop is built into the sliding arm.
- The optional sliding arm adapters (in different heights) bridge the distance between the drive and the sliding arm.

#### 3.6 BDE-D

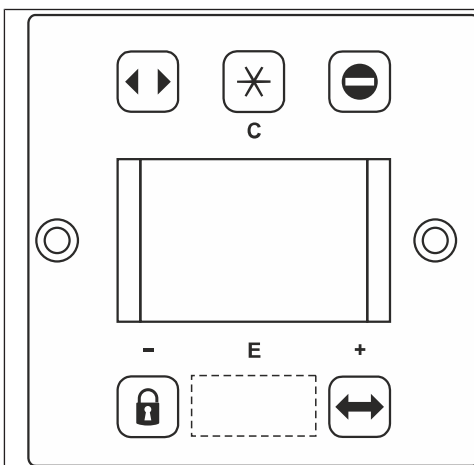

The BDE-D external control unit controls the door operator. It can be used to select 5 operating modes.

The LCD display with backlight shows the door status by means of symbols and text.

Further information can be found in the operating instructions of the BDE-D.

The installation must be carried out by qualified personnel.



### 3.7 Components

The swing door operator forms part of an electromechanical swing door system and comprises the following main components:

<b>Control unit:</b>	Intelligent, self-learning microprocessor-controlled control system
<b>Drive unit:</b>	Low maintenance DC geared motor with electronic path measurement and integral thermostatic protective switch, gear box with adjustable spring tension
<b>Power supply:</b>	Compact 230 V power supply with integral input filter
<b>Control unit:</b>	With simple mechanical operating unit and/or optionally with comfortable, programmable electronic operating unit BDE-D
<b>Lever System:</b>	Power transmission to the door leaf with standard lever pushing or sliding lever pulling / pushing
<b>Locking (optional):</b>	Possibility on site to connect an electrical door opener (24 VDC)
<b>Sensors:</b>	Aesthetic release and self-monitoring safety devices with adjustable sensitivity ensure optimal, smooth and safe operation of the door system

### 3.8 Functional description

The drive is designed so that it functions like a normal door closer when currentless. It can therefore be easily opened by hand and is closed by the energy stored in the spring, damped by the motor which acts as a generator.

If the drive is connected to the mains, the opening and closing movements are motor-supported.

The following functions are solely intended for the safety of the user:

#### Obstacle detection:

If the door hits an obstruction while opening, it stops immediately and records the position of the collision. The drive attempts to briefly reach the open position during the hold-open time. Once the hold-open time elapses, the door closes and, during the next opening, the obstruction position is passed over very carefully in slow mode. This prevents a second hard impact.

#### Reversing:

If the door hits an obstruction while closing, re-opening is immediately initiated.

### 3.9 Functional description Inverse

The drive with inverse function is constructed in such a way that the door can be used without electricity. The drive opens with the energy stored in the spring, damped by the motor acting as a generator. Escape route door openers of the type 331 and 332 can be used to keep the door shut without electrical power. (Escape and rescue route doors have to open without electrical power.)

If the door drive runs on AC power, opening and closing motions are motor assisted. Thereby, the door can be halted both at opened and at closed position (electromagnetic brake).

Nevertheless, that does not make the door resistant against brake-ins. The inverse door drive does allow neither manual operation nor touch control. The door can be opened by hand and is assisted by spring tension. But the door has to be pushed against this spring tension for closing. An electrical lock is necessary to keep the door shut, but it will release the door in case of an alarm or in case of a power failure.

In standard operation mode "automatic mode" the door opens due to an actuating device (e.g. motion detector) triggered by approaching persons or objects. After the door open time has passed, the door closes unless a new opening impulse ensues.

In operation mode "locked" the door can only be opened by triggering an optional key pivot contact (SSK). After the SSK door open time has passed, the door closes unless a new opening impulse ensues.

The following functions are provided exclusively for the safety of the user:

**Collision detection:** If the door strikes an obstacle while **opening**, it stops immediately and stores the position of the impact. During the time delay, the drive briefly tries to reach the open position. Once the time delay has expired, the door closes, and, when next opened, the door passes the impact position very carefully in slow mode. This prevents a further violent impact.

### 3 Description

**Reversing:** If the door strikes an obstacle when **closing**, it is reopened immediately. The obstacle's position is saved to the door drive, and the position is approached slowly during the next closure.

#### 3.10 Low energy drive

In the parameterisation of the Low Energy door type „Low Energy“ the drive acts as an automatic low energy operator. The opening and closing speeds are limited and the operator is more sensitive in case of a collision. The closing action takes place using spring force and reduced kinetic energy.

In the currentless state, the door can be opened manually and closes automatically with the energy stored in the spring.



#### CAUTION

##### Risk of injury from bumping against the door leaf

The low-energy drive is classified as non-hazardous. Nevertheless, collisions with certain groups of people can cause risk of injury.

- Clarify whether the residual risk for elderly and frail persons or persons with physical limitations is low.
- Observe the opening or closing speed of the door.
- Do not rush between a closing door leaves.

#### 3.11 Primary / secondary application

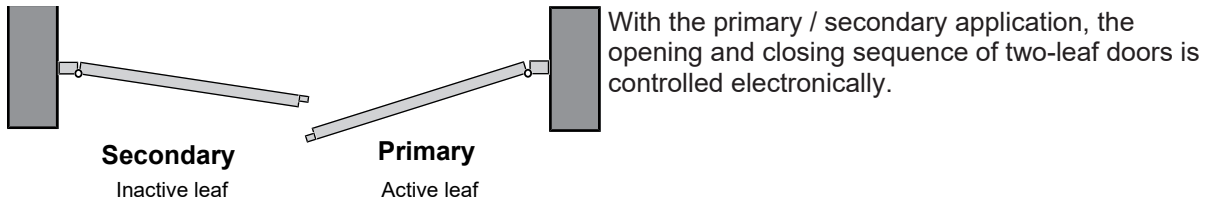

The two operators communicate with each other via an interface so that the safety functions such as reversing and obstacle detection remain in place.



#### NOTICE

The functions of the primary / secondary operator correspond to those of a standard operator.

##### 3.11.1 Functions

**Obstacle detection:** If the door hits an obstacle when opening, it stops immediately and saves the position of the collision. During the hold open time, the operator briefly attempts to reach the open position. Once the hold open time has elapsed, the door closes and the obstacle position is passed over more slowly the next time it opens. This prevents another hard impact.

**Reversing:** If the door hits an obstacle when closing, a reopening is initiated immediately (reversing). The obstacle position is saved in the door operator and this position is approached gently the next time the door is closed.

**Operation:** Three operation modes can be set using the built-in toggle switch BDI.

**Primary / secondary:** A primary / secondary system can only be operated via the toggle switch BDI of the primary operator. This switch position also affects the secondary operator.

## 4 Technical data

Dimensions OFFSET:	561 x 258 x 152 mm (LxWxD)
Dimensions CENTER:	641 x 231 x 152 mm (LxWxD)
Operating voltage:	100 - 240 VAC, 50/60 Hz
Power consumption:	Standby 25 W, Nominal power 67 W
Torque maximum:	80 Nm
Weight door leaf maximum:	600 kg
Opening angle:	Adjustable from 70° to 120°
Hold open time:	Adjustable from 0 to 60 seconds (40 steps)
Opening speed:	Adjustable from 3 to 20 seconds (40 steps)
Closing speed:	Adjustable from 5 to 20 seconds (40 steps)
Noise emission:	< 45 dB
Protection class:	IP 69
Temperature range:	-15° to +50° C
Humidity range:	up to 85% relative humidity, non-condensing

## 5 Operation

### 5 Operation

**See also:**

📄 Configuration C 127 X [▶ 23]

📄 Configuration FEM V1\_10 with STG127 V2\_40\_E [▶ 24]









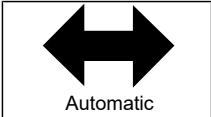

#### 5.1 Control panel BDE-D

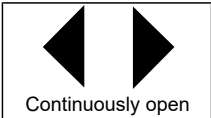
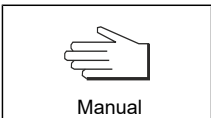
##### 5.1.1 Operation modes and button functions

The buttons on the control panel BDE-D are used to set the door system operation modes in the main menu. The parameters of the door system are set in the sub menu.

The button functions are divided into main menu and sub menu.

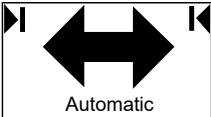
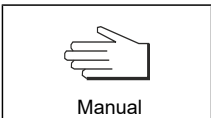
##### Main menu

Button	Name	Operation	Function	Display on LCD
	Automatic button	Press button 1 x	Automatic operation via sensors	 Automatic
	Continuously open button	Press button 1 x	For sliding door operator and swing door operator: continuously open, sensors disabled	 Continuously open
		Press button 2 x or hold it down for 2 seconds	For sliding door operator: manual operation	 Manual
	One-way button	Press button 1 x	Passage only possible from one direction	 One-way
	Locking button	Press button 1 x	Door closed, sensors disabled	 Locked
		Press button again	The door opens again, closes, and locks again. Can be opened with a key (optional).	 Locked
	Star button	Press button 1 x	For sliding door operator: Reduced open width	 Automatic
		Press button 1 x	For swing door operator: manual operation	 Manual
	Menu button	Restart control device: press button for 5 seconds Restart hardware BDE-D: press button for 12 seconds	Access to parameter menu Enable control lock Restart control device Restart hardware BDE-D	

Sub menu



**NOTICE**

The main menu is returned to automatically 3 minutes after the last entry.

Button	Name	Operation	Function	Display on LCD
E 	Enter button	Press button 1 x to go to the next sub menu.	Select menu item, confirm entry	Opening speed 
+ 	Plus button	Press button 1 x to go down.	Navigate downwards in the menu	Parameter Driving cycle Time delay open Operator
		Press button 1 x to increase the value.	Move the slide control to the right to increase the value	Closing speed 
- 	Minus button	Press button 1 x to go up.	Navigate upwards in the menu	Parameter Driving cycle Time delay open Operator
		Press button 1 x to reduce the value.	Move the slide control to the left to reduce the value	Closing speed 
 C	Clear button	Press button 1 x to go to the previous menu.	Leave the menu item without saving.	Parameter Driving cycle Time delay open Operator



5.1.2 Perform reset

Reset controller

Step	Button	Operation	Function	Display on LCD
1.	E 	Press button for 5 seconds	Perform controller reset	No Reset controller? Yes
2.	 C	Press button 1 x	Cancel reset	
	E 	Press button 1 x	Perform reset	

## 5 Operation

### Reset control panel

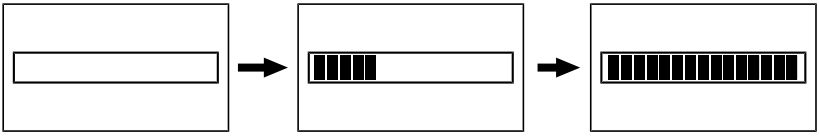
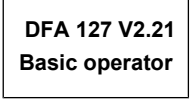
Step	Button	Operation	Function	Display on LCD
1.		Press button for 12 seconds	Perform control panel reset	
2.				
3.			The connection has been established	





#### 5.1.3 Display system information

Information about the door system, such as software version, door type, or servicing status, can be shown on the display.

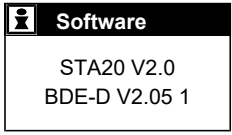

### NOTICE

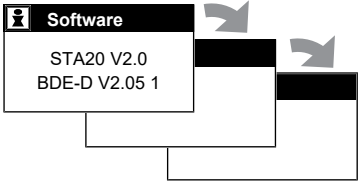
The main view is returned to by scrolling or automatically after 20 seconds.

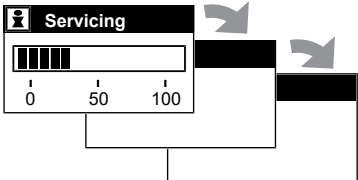
Step	Button	Operation	Function	
1.		Press button for approx. 2 seconds	Software information is displayed	
2.		Press button 1 x	Scroll through the information and/or return to main view	
3.		Press button 1 x	Scroll through the information and/or return to main view	

#### 5.2 Parameter overview

Factory settings: **Basic operator** (Full Power)



### NOTICE

Parameterization of the swing door operator can only be carried out with the optional electronic BDE-D, the App i-record or the service and flash programmer FPC 902 or the test box.



### NOTICE

Please always leave the parameter list in the drive even when replacing the STG!

System C 127 X SU parameter overview				STG 127					
D = Value will reset after default parameter loading S = Programming of slave 1 or slave 2 M = Parameter modification via MFT (key) on STG (technical level)				<input type="checkbox"/> Master <input type="checkbox"/> Slave					
PARAMETER				Parameter value (factory settings printed bold), [ ] according to door type					
Description	D	S	M	1	2	3	4	5	6
<b>DRIVING CYCLE</b>									
↳ Closing speed	D			<b>1</b>	(Speedo)				
↳ Opening speed	D			<b>8</b>	(Speedo)			<b>DIN: &gt; 1.5 s &lt; 4 s</b>	
↳ Acceleration	D		M	<b>12</b>	(Speedo)			<b>Different accelerations</b>	
↳ Latch check	D		M	<b>0</b>	(Speedo)			<b>Start latch check by closing</b>	
↳ Force when closing	D		M	<b>0</b>	(Speedo)			<b>DIN: 0</b>	
<b>TIME DELAY OPEN</b>									
↳ Time delay open	D			<b>2</b>	(Speedo)				
↳ Time delay SSK	D			<b>4</b>	(Speedo)				
<b>DRIVE</b>									
↳ Opening angle	D	S		<b>35</b>	(Speedo)			<b>DIN: min. 95°</b>	
↳ Collision close	D	S	M	<b>20</b>	(Speedo)				
↳ Collision open	D	S	M	<b>20</b>	(Speedo)				
↳ Brake			S M	<b>Without</b>	Closed posit.	Open posit.	Open/Clos. pos.		
↳ Types of arms			S M	<b>Standard arm</b>	<b>Sliding pulling</b>	Sliding pushing	Inheader		
↳ Inverse			M	<b>Disabled</b>	Enabled				
↳ Spring type			S M	<b>Unknown</b>	EN 4	EN 5	EN 6		
↳ Limit open	D	S	M	<b>Disabled</b>	Enabled				
↳ Momentum	D	S	M	<b>Disabled</b>	Enabled				
<b>ENTRANCE SYSTEM</b>									
↳ Measure A			M	<b>0</b>	(Speedo)				
↳ Measure G			M	<b>0</b>	(Speedo)				
↳ Fire alarm			M	<b>Disabled</b>	Enabled				
↳ Control			S M	<b>Single control</b>	Master control	Slave control	Master Interlock	Slave Interlock	
↳ Interlock			M	<b>Disabled</b>	All operation modes	<b>Only one-way /locked</b>			
↳ Door type			M	<b>Basic operator</b>	USA	US Low Energy	EU Low Energy	UK	UK Low Energy
				Airport Brussels	Default 1	Nordics High	Nordics Low	C 127 X <sup>[1]</sup>	
<b>MS 2-LEAVES</b>									
↳ Function AKA	D		M	<b>Master+slave</b>	Master only				
↳ Overlap	D		M	<b>5</b>	(Speedo)			<b>0 = No overlap</b>	
↳ Open sequence	D		M	<b>5</b>	(Speedo)			<b>0 = Simultaneous opening</b>	
↳ Close sequence	D		M	<b>15</b>	(Speedo)			<b>0 = Simultaneous closing</b>	
<b>MANUAL CONTROL</b>									
↳ During closing	D		M	<b>Disabled</b>	Enabled				
↳ When locked	D		M	<b>Disabled</b>	Enabled				
↳ When one-way	D		M	<b>Disabled</b>	Enabled				
↳ When automatic	D		M	<b>Disabled</b>	Enabled				
↳ Collision	D		M	<b>Disabled</b>	Enabled				
↳ Support during closing	D		M	<b>Disabled</b>	Constant	Cumulative	Final bang	Slowly, cumulative	Slowly, final bang
				Final bang stronger	Slow, final bang stronger				
↳ Active sensors	D		M	<b>Disabled</b>	SIS disabled	SIS enabled	SIS enabled AUTO	SIS without	
↳ Closing speed	D		M	<b>20</b>	(Speedo)				
↳ Opening assist	D		M	<b>0</b>	(Speedo)				
<b>CONTROL PANEL</b>									
↳ BDE-M (mech. panel)	D	S	M	<b>3 Pos. (AUTO)</b> Manual; Automatic; Cont. open	4 Positions Automatic; Manual; Cont. open; Locked	3 Pos.(OFF-A) Automatic; OFF; Cont. open	3 Pos. (OFF-M) Manual; OFF; Cont. open	3 Pos.(Lock-A) Automatic; Locked; Cont. open	3 Pos(Lock-M) Manual; Locked; Cont. open
↳ BDE-D				4 Positions Automatic; One-way; Cont. open; Locked					
↳ Language			M	Deutsch	Français	<b>English</b>	English US	Español	Nederlands
				Danish	Slovenscina	Polski	Magyar	Italiano	Czech
				Türkçe					
↳ Keyboard	D		M	<b>Normal</b>	OFF-Mode				
↳ Contrast BDE 1			M	<b>20</b>	(Speedo)				
↳ Contrast BDE 2			M	<b>20</b>	(Speedo)				
↳ Brightness BDE 1			M	<b>20</b>	(Speedo)				
↳ Brightness BDE 2			M	<b>20</b>	(Speedo)				
↳ Light time			M	<b>10</b>	(Speedo)			<b>40 = permanent lighting</b>	
<b>LOCKING</b>									
↳ Locking function			M	<b>Normally locked</b>	1way locked	Always locked			
↳ Lock type			M	<b>Standard</b>	Locking bolt	Magnet	Pulse		
↳ VRR manually			S M	<b>Disabled</b>	Enabled				
↳ Start delay			M	<b>0</b>	(Speedo)				
<b>CAN-BUS</b>									
↳ (Units connected to CAN bus)	D		M	FEM 0... FEM 2	AKI 1	SI 1	AKA 1	SA 1	AKI 1
				SI 2	AKA 2	SA 2			
<b>INPUT/OUTPUT</b>									
↳ STG									
↳ AUX1 IN	D		M	<b>Disabled</b>	BEA Bodyguard	Closing button			
↳ AKA IN	D		M	<b>AKA</b>	Railbeam				
↳ AKA_IN_F	D		M	<b>Disabled</b>	Inactive by 1way and locked				
↳ AUX1 OUT	D		M	<b>Disabled</b>	BEA Bodyguard	Test sensors	Locked	Closed	Gong
↳ Sequential	D		M	<b>Disabled</b>	Seq. AKI / AKA	Seq. AKI	Seq. SSK		
↳ EMERG. STOP Reset				Disabled	<b>Enabled</b>				
<b>MISCELLANEOUS</b>									
↳ Push to actuate to open	D	S	M	<b>Disabled</b>	Normal (motored)	Slow (motored)			
↳ Alarm display									
↳ Time activation	D	S	M	<b>18</b>	(Speedo)				
↳ Time safety	D	S	M	<b>18</b>	(Speedo)				

Order number:	Client:
Programming by end customer / changes	Date / Initials

 This parameter overview shows all possible settings. Depending on drive type and configuration the access is restricted.

System DFA 127 parameter overview				FEM 1 STG 127				≥ V1.10 ≥ V2.40	
D = Value will not be reset after loading default parameter M = Parameter modification via MFT (key) on STG (technical level)									
PARAMETER FEM 1				Parameter value (factory settings printed bold)					
Description	D	M	1	2	3	4	5	6	
<b>FEM 1</b>				<b>FEM 1 in use with STG 127</b>					
L ▶ FEM type		M	<b>Basis</b>	Interlock	I/O-Set 1				
<b>INPUT FEM 1</b>									
L ▶ AUX10_IN [64/65]	D	M	<b>Disabled</b>	S_AUS					
L ▶ AUX11_IN [66/67]	D	M	<b>Disabled</b>	SEA					
L ▶ AUX12_IN [68/69]	D	M	<b>Disabled</b>	SFS_IN					
L ▶ AUX13_IN [70/71]	D	M	<b>Disabled</b>						
<b>OUTPUT FEM 1</b>				All outputs can be configured according to AUX1x_OUT					
L ▶ AUX1x_OUT	D	M	<b>Disabled</b>	Alarm output	Locked	Closed	Open	SAMP	
			SAA	SFS_OUT	OM Automatic	OM One-way	OM Locked	OM Cont. open	
			OM Manual	OM OFF	Locking error	Emerg. stop or open	Maintenance is due	Maint. time exceeded	
L ▶ AUX10_OUT [73/74]	D	M	<b>Disabled</b>						
L ▶ AUX11_OUT [76/77]	D	M	<b>Disabled</b>						
L ▶ AUX12_OUT [79/80]	D	M	<b>Disabled</b>						
L ▶ AUX13_OUT [82/83]	D	M	<b>Disabled</b>						
L ▶ AUX14_OUT [88/89]	D	M	<b>Disabled</b>						
L ▶ AUX15_OUT [90/91]	D	M	<b>Disabled</b>						
L ▶ AUX16_OUT [92/93]	D	M	<b>Disabled</b>						
L ▶ AUX17_OUT [94/95]	D	M	<b>Disabled</b>						
L ▶ AUX18_OUT [96/97]	D	M	<b>Disabled</b>						
L ▶ AUX19_OUT [98/99]	D	M	<b>Disabled</b>						
L ▶ AUX1A_OUT [100/101]	D	M	<b>Disabled</b>						
L ▶ AUX1B_OUT [102/103]	D	M	<b>Disabled</b>						
L ▶ AUX1C_OUT [104/105]	D	M	<b>Disabled</b>						
L ▶ AUX1D_OUT [106/107]	D	M	<b>Disabled</b>						

Instruction FEM 1: Not configurable functions in use with STG 127 are marked with an (\*).

Instruction software: The possibilities of FEM 1 depend chiefly on the software version of the control.



## 5.5 Description of parameters

W = Factory settings: **Basic drive (FP)**

PARAMETER	W	REMARK
DRIVING CYCLE		
→ closing speed	1	Speed when closing the door. 0 = lowest speed 40 = highest speed – The maximum speed depends on the opening angle and acceleration.
→ Opening speed	8	Change value to 8 after reset! Driving speed of the opening door. 0 = lowest speed 40 = highest speed – The maximum speed reachable depends upon the opening angle and the acceleration setting. – DIN: > 1.5 s <4 s
TIME DELAY OPEN		
→ time delay open	2	Determines how long the door remains open after it has been opened by a trigger signal. 0..20 = 0 to 20 seconds, increment 1 s 21..40 = 22 to 60 seconds, increment 2 s – The time delay open starts when all trigger and safety signals for closing stop.
→ SSK time delay open	4	Determines the minimum time the door remains open after it has been opened by a trigger signal of the type SSK. 0..20 = 0 to 20 seconds, increment 1 s 21..40 = 22 to 60 seconds, increment 2 s – The hold open time starts when all trigger and safety signals for closing stop.



### NOTICE

The open duration can be reduced when sensors are used which keep the door open, for example *Time delay*.

OPERATOR		
→ opening angle	35	The opening angle is determined during the teach-in run and corresponds to the value 40. 0 = minimum opening angle 40 = maximum opening angle – <b>DIN:</b> min. 95°

## 6 Inspection and maintenance

Regular inspection and maintenance of the system by trained and authorized personal from the manufacturer, is the best guarantee for long life and trouble-free secure operation.

These control and maintenance operations are required at regular intervals, following the manufacturer's instructions and the relevant legal requirements.

### 6.1 General remarks



#### DANGER

**Danger to life due to electric current!**

- a) In case of contact with live parts, there is an immediate danger to life due to electric shock. Damage to or removal of the insulation or individual components can be life-threatening.
  - ⇒ Before starting work (cleaning, maintenance, replacement) on active parts of electrical systems and equipment, ensure that all poles are voltage free and that this is maintained for the duration of the work.
  - ⇒ Keep moisture away from live parts. This can lead to a short circuit.
  - ⇒ Never bridge fuses or put them out of operation.
  - ⇒ Do not connect the power supply until all work has been completed.
  - ⇒ Have work on the electrical system performed by qualified personnel only.



#### IMPORTANT

**Specific checks and maintenance may only be carried out by a specialist or a person trained for this purpose. The authorization of these persons is carried out exclusively by the manufacturer. The scope, result and time of the periodic inspections and maintenance must be recorded in an inspection book and a checklist. These documents must be kept by the operator.**

According to current legislation, the operator of an automatic door system is responsible for its maintenance and safety.

With the care of the installation by the operator, accidents or defects can be avoided.

### Testing

Type of test	Action
Visual inspection	Check door leaves, guides, bearings, limiting devices, sensors, and the securing of crushing and shearing points for damage.
Mechanical inspection	Check fastenings for tight fit.
Safety check (exit and escape routes)	Check sensors, safety devices, and monitoring devices for tight fit and damage.
Function testing	Check functioning of switches, operators, controllers, power or energy storage devices, and sensors. Also check the adjustment of the safety devices and the setting of all movement sequences including the end points.
Test run	Final overall review is carried out.

### Servicing

Type of servicing	Action
Adjustment and cleaning	Clean and adjust bearings, sliding points, and power transmission. Check relevant fastening screws and retighten if necessary.

For documentation and information purposes, the testing and servicing work as well as the condition of the system are recorded in a test log book. The test log book must be kept for at least one year or until the next testing/servicing.



**IMPORTANT**

The testing and/or servicing interval according to the manufacturer's specification is at least 1 to 2 times a year.



**IMPORTANT**



The recommended and planned spare and wear parts can be requested from your service center.

6.2 Door care

The entire system, including the sensors and safety devices, can be cleaned with a moist cloth and standard commercial cleaners (non-scouring, do not use any solvents). First test the cleaners on a hidden (not easily visible) place. Keep all guides free of dirt.



**NOTICE**

It is recommended that for carrying out this work, the operating mode  (Locked) or  (Continuously open) be used, so as to avoid possible injuries from unwanted door movements.

6.3 Maintenance and regular inspection

A safety inspection must be carried out before initial start-up and as required, as well as in accordance with the applicable regulations – **but at least twice a year**. We recommend having maintenance carried out at the same time.

A safety-related inspection must be performed by a competent service technician or an authorized partner.

Maintenance due is displayed on the BDE-D operating unit if this function has been activated. The interval for the output of this message is defined by the number of opening cycles and/or after a certain operating time has elapsed.

Regular inspection and maintenance of the equipment by trained personnel, authorized by the manufacturer, provides the best guarantee for a long service life and trouble-free safe operation.

**We recommend concluding a service agreement with the service center responsible for your area.**



**IMPORTANT**

A list of the recommended and planned spare and wear parts can either be seen in the appendix or can be requested from your service center.

6.4 Logbook



**IMPORTANT**

The following example of a test book serves only as a template. According to local regulations such a logbook must be attached to the door installation and all interventions and recurrent controls must be recorded in it.

Date	Error description / status-no.	Troubleshooting / maintenance / recurrent controls	Defects corrected / Parts replaced	Service-technician signature

## 6 Inspection and maintenance

### 6.4.1 General information

Manufacturer – Information	
Name:	
Street:	
City:	
Telephone:	
Fax:	
E-Mail:	

Distributor – Information	
Name:	
Street:	
City:	
Telephone:	
Fax:	
E-Mail:	

Location of system installation (Project information)	
Name:	
Street:	
City:	
Telephone:	
Fax:	
E-Mail:	

System – Information	
Conf. serial – No.:	
System – Type:	
System – Installation date:	

### 6.4.2 Operator duties

Personal protection requires compliance with the standards and guidelines for publicly accessible facilities.

According to applicable standards and guidelines, automatic door systems must be tested and serviced by qualified persons.

The system operator is responsible for carrying out testing and servicing.



#### NOTICE

The installation must be inspected during the function and safety check for imbalance and signs of wear or damage to cables, springs and fastening parts.

The equipment must NOT be used if repair or adjustment work needs to be carried out.



## CAUTION

**Risk of malfunctions, material damage or injuries due to insufficient or missing cleaning or care!**

- a) Insufficient or inattentive cleaning or care of the system can lead to malfunctions, damage to property or injury to persons.
- ⇒ Check the sensors regularly for dirt and clean them if necessary.
  - ⇒ Regularly remove dirt accumulations in the floor rail or under the floor mat.
  - ⇒ Keep the system free from snow and ice.
  - ⇒ Do not use aggressive or caustic cleaning agents.
  - ⇒ Use road salt or loose chippings only conditionally.
  - ⇒ Lay the floor mat without folds and flush with the floor.
  - ⇒ Equipment required for cleaning purposes such as ladders or similar must not be leaned on or attached to the system.

### Tasks system operator

Task	Personnel	Time of implementation	Entry in the inspection book
Maintenance and cleaning of the sensors for safety and triggering	System operator	Weekly, or as required	No
Function and safety check	System operator	Monthly	No
Function test for fire doors	System operator	Monthly, or according to country-specific standards and guidelines	No

### Tasks of qualified person

Task	Personnel	Time of implementation	Entry in the inspection book
Acceptance test	Qualified person	After assembly of the door system ready for operation	Yes
Servicing	Qualified person	1 x annually, or according to country-specific standards and guidelines	Yes
Test (inspection)	Qualified person	1 x annually, or according to country-specific standards and guidelines	Yes
Test (inspection) for door systems in escape routes	Qualified person	2 x annually, or according to country-specific standards and guidelines	Yes
Testing of fire doors	Qualified person	1 x annually, or according to country-specific standards and guidelines	Yes
Testing (inspection) for fire doors	Qualified person	1 x annually, or according to country-specific standards and guidelines	Yes
Servicing for fire doors	Qualified person	1 x annually, or according to country-specific standards and guidelines	Yes

#### 6.4.3 Commissioned technician

Technicians are people:

- that on the basis of their technical training, knowledge, experience and work, perform their assigned test properly and identify and evaluate potential hazards.
- that have sufficient knowledge in the field of automatic door systems, relevant national safety regulations, accident prevention regulations, directives and generally recognized technical regulations, so they can judge the secure working condition of automatic door systems. These people include, for example, technicians from the manufacturing or supplying company, relevantly experienced, trained personnel authorized by the manufacturer or other persons with appropriate expertise.

## 6 Inspection and maintenance

---

Experts must submit their assessment objectively from the standpoint of personal and operational safety without being influenced by other requirements, such as i.e. economic circumstances.

### 6.4.4 Legal principle



#### NOTICE

**According to EN 16005 / DIN 18650 / Machinery Directive, the system must be inspected by an expert before initial commissioning and then according to the manufacturer's instructions or at least once a year.**

The special significance for personal protection requires compliance with these special regulations.

### 6.4.5 Extent of the inspection

The test is carried out according to the manufacturer's test instructions. The result of the test is recorded in a test protocol and recorded in the test logbook.

The inspection usually takes place at the same time as the maintenance of the system.

The inspection also checks whether no changes have been made to the system since the last inspection and whether it meets the current safety requirements.

### 6.4.6 Requirements for documentation

Extent, results and dates of the periodic inspections, must be documented and kept by the operator in an Inspection- and Maintenance log book.

The contractor / operator must be informed of the results in writing.

The contractor / operator requires the inspection report (check list) for proof that the periodic inspection was performed and/or as documentation for construction authorities or accident and liability insurances, etc.

# 7 Malfunctions

## 7.1 Status displays

Malfunctions are shown on the LCD display. If there is a malfunction, the display switches between the operating mode level to the error display / light and dark as shown in the following figure.

Every 2 seconds the backlight changes flashing between black and white.

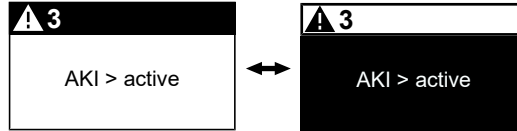







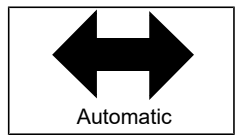

Status displays with a "W" are warnings for which no switching of the fault output relay takes place.

The status can be cleared/reset by pressing the key  for 5 seconds. This restarts the control unit.

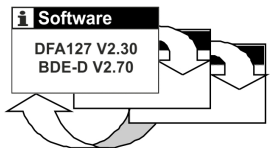

### NOTICE

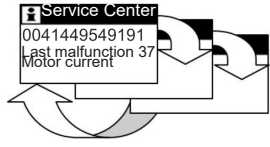
Phone number and maintenance are only displayed if this has been activated by the Service department.

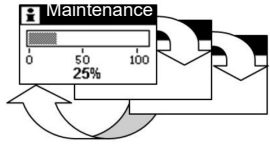
Button	Operation	Function	Display on LCD
	Press button 1 x	Return to the main menu for 4 seconds	
	Press button for 2 seconds	Information about the drive system e.g. software version	
	Press button 1 x	Scroll through the information	
	Press button 1 x	Scroll through the information	
	Press button 1 x	Scroll through the information	

Multiple malfunctions can be displayed, e.g. 1 / 2. If there are multiple malfunctions, they are numbered as follows.

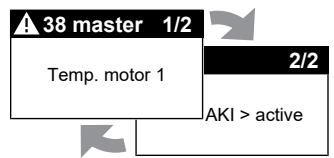
Button	Operation	Function	Display on LCD
	Press button 1 x	Scroll through the malfunction displays	

The return to the main view is done by keystroke or automatically after 20 seconds.



### NOTICE

If the cause of the error has not been eliminated, the status message is displayed again when the error occurs again.

## 7.2 Troubleshooting



### NOTICE

The following malfunctions on the door can only be corrected if an electronic control unit with display is present.



### NOTICE

A detailed description of the error messages can be found in the book B8A 102-020401152.

Malfunction	Cause	Measure	Personnel
Display shows a malfunction message.	Malfunction present	Restart controller and/or control panel.	System operator
Door does not work.	No power connected.	Check power connection.	System operator
	Incorrect operation mode selected.	Check operation mode.	System operator
	Status LED flashing	Restart controller and/or control panel.	System operator
	Malfunction message on the display of the BDE-D	Restart controller and/or control panel.	System operator
	Defective	Close the door manually and notify a service engineer.	System operator
Malfunction message still present after restart.	Malfunction could not be rectified.	Qualified personnel are required to rectify the malfunction.	Qualified personnel
		Show and read out system information about the door on the display. Notify service center. If necessary, close the door manually.	System operator
Signal tone every 5 seconds (only with battery pack option)	No power present.	Switch on the mains power supply.	System operator
	Mains fuse defective.	Replace the fuse.	System operator
	Fuse on the operator's power supply unit defective.	Replace the fuse.	Qualified personnel



## 8 Taking out of service and disposal

### 8.1 Decommissioning

When shutting down or taking out of service, the system is disconnected from the mains supply and any existing battery is unplugged.



#### NOTICE

After each temporary shutdown a new commissioning must be carried out.

### 8.2 Dismantling and disposal



#### IMPORTANT

All machine parts must be sorted by type of material and disposed according to local regulations and guidelines.



#### NOTICE

The door systems can be completely disassembled in reverse order.

The installation mainly consists of the following materials:

#### Aluminum:

- Linking profiles
- Gearbox, Drive panel
- Door wing profiles and side profiles
- Various profiles and small parts

#### Steel / iron parts:

- Stainless steel casing, Floor panel, Box recess for floor installation
- Optional spacer or reinforcement profiles
- Gear components, springs
- Various small parts like fittings, covers, linking parts, etc.

#### Glass:

- Door wings and side panels

#### Various electronic and electromechanical components:

- Sensors, control and operator components
- Batteries and rechargeable batteries

#### Various plastics:

- Rollers
- Cable clips, coupling and linking parts
- Sealing profiles
- Casing of electromechanical components and sensors



Your global partner for entrance solutions