



record K 32 SU / K 42 SU

User manual

Your global partner for entrance solutions

www.record.group

Document identification

Article nr.: 121-006454663
Version: 1.1
Publication date: 05/07/2022

Translation of the original manual

Subject to technical modifications
Copyright © agtatec ag

Table of Contents

List of changes	5
1 Safety	6
1.1 Presentation of warning signs	6
1.2 Intended purpose of use	6
1.3 General hazards	7
1.4 State of technology	9
1.5 Personal protective equipment	9
1.6 Spare parts and liability	10
2 General information	11
2.1 Purpose and use of the instructions	11
2.2 Copyright	11
2.3 Product identification	11
2.4 Manufacturer BLASI GmbH	11
2.5 Target groups	11
2.6 Definition of terms	12
3 Description	13
3.1 Graphical illustrations	13
3.1.1 Main mechanical components	13
3.2 Description of the door	14
3.3 Safety features and control elements K32 / K42	14
3.3.1 Legend for safety features and control elements	15
3.3.2 BDE-D-KTA control unit	17
3.3.3 Emergency stop button	18
3.3.4 Information on motion detectors	18
3.3.5 Vertical safety sensors drum edge	18
3.3.6 Information on safety strips	18
4 Options	19
4.1 Electromagnetic turnstile lock (Fail Secure)	19
4.2 Turnstile bar-bolt lock	19
4.3 Lock mechanism status indicator and door position indicator	19
4.4 BDE-V key switch	19
4.5 Key pivot contact (SSK)	20
4.6 Disabled button	20
4.7 Start button	21
4.8 Key emergency operation switch	21
4.9 BDE-Lock key switch	22
4.10 Vertical sensors strips drum walking area	22
4.11 Air curtain control	22
4.12 Foldable turnstile wings and/or foldable drum walls	22
4.13 Light switch	23
4.14 Lighting control	23
4.15 Night shield	24
4.15.1 Manual night shield	24
4.15.2 Night shield - deadman	24
4.15.3 Fully automatic night shield	24
5 Specifications	26
5.1 Environmental conditions	26
5.2 Electric specifications of the door	26
5.3 Electrical specifications power supply	26

Table of Contents

5.4	Electrical specifications of the door control KST200.....	26
5.5	Electrical lighting specifications	26
5.6	Sound pressure level	27
6	Operation.....	28
6.1	Operating mode symbols	28
6.2	Instructional symbols	28
6.3	Menu display.....	28
6.4	Status display	29
6.5	Error display.....	29
6.6	Operating modes selection	29
6.7	Special function selection	30
6.8	Operating lock via the keyboard	30
7	Servicing and maintenance	31
7.1	General remarks	31
7.2	Monthly inspection work performed by the operator	31
7.3	Cleaning and care.....	33
8	Malfunctions	35
8.1	Conduct during malfunctions	35
8.1.1	Troubleshooting options	35
8.1.2	Tips for troubleshooting	35
8.1.3	Status display and troubleshooting BDE-D-KTA.....	36
8.1.4	Restarting the door control.....	43
8.2	Function during a power failure	44
9	Taking out of service and disposal.....	45
9.1	Decommissioning	45
9.2	Dismantling and disposal.....	45

List of changes

Change	Location
Complete revision of all Sections and content	Entire document
New Section structure	Entire document
Revision of all graphics	Entire document

1 Safety

1 Safety

1.1 Presentation of warning signs

Various symbols are used in this guide for easier understanding:



NOTICE

Useful advice and information to ensure correct and efficient workflow of the system.



IMPORTANT

Specific details which are essential for trouble-free operation of the system.



IMPORTANT

Important details which must be read for proper function of the system.



CAUTION

Against a potential hazardous situation that can lead to minor personal injury and property damage.



WARNING

Against a latent hazardous situation that can lead to severe injuries or death and cause substantial property damage.



DANGER

Against an imminent hazardous situation that can lead to severe injury or death.



DANGER

Against an imminent or latent hazardous situation that could lead to electric shock and cause serious injury or death.

1.2 Intended purpose of use

The system is designed exclusively for use as a pedestrian passage. The installation must only occur in dry areas. If there are deviations then proper waterproofing and water drains will be required on-site.

Any other application or use beyond this purpose is not considered to be an intended purpose. The manufacturer bears no liability for any resulting damage; the operator alone shall bear the associated risk.

The intended purpose also includes observation of the operating conditions specified by the manufacturer, in addition to regular care, maintenance and repair.

Interventions in or alterations to the installation performed by non-authorized maintenance technicians exclude the manufacturer's liability for consequential damages.

1.3 General hazards

The following section lists hazards that can be caused by the system even when used as intended. To reduce the risk of malfunction, damage to property or injury to persons and to avoid dangerous situations, the safety instructions listed here must be observed.

The specific safety instructions in the other sections of this manual must also be observed.



IMPORTANT

The country-specific regulations must be observed and complied with!



IMPORTANT

To avoid malfunctions, moving objects such as flags or parts of plants must not be allowed to enter the detection range of the sensors.



CAUTION

Risk of malfunctions, material damage or injury due to improper settings!

- a) Improper settings can lead to malfunctions, material damage or personal injury.
 - ⇒ Do not disconnect the system from the power supply overnight.
 - ⇒ Settings should only be made by personnel qualified to do so.
 - ⇒ Do not disassemble, put out of operation or manipulate safety devices.
 - ⇒ Have faults rectified by specialist personnel or by personnel qualified to do so.
 - ⇒ Have service and maintenance carried out according to locally applicable regulations or according to a maintenance contract.



CAUTION

Risk of malfunctions, material damage or injuries due to insufficient or missing cleaning or care!

- a) Insufficient or inattentive cleaning or care of the system can lead to malfunctions, damage to property or injury to persons.
 - ⇒ Check the sensors regularly for dirt and clean them if necessary.
 - ⇒ Regularly remove dirt accumulations in the floor rail or under the floor mat.
 - ⇒ Keep the system free from snow and ice.
 - ⇒ Do not use aggressive or caustic cleaning agents.
 - ⇒ Use road salt or loose chippings only conditionally.
 - ⇒ Lay the floor mat without folds and flush with the floor.
 - ⇒ Equipment required for cleaning purposes such as ladders or similar must not be leaned on or attached to the system.



CAUTION

Risk of material damage or injury due to unforeseen opening, closing or turning of the door!

- a) The door can open, close or turn unexpectedly. This may result in damage to property or injury to persons.
 - ⇒ No persons may be present in the opening area of the system.
 - ⇒ Ensure that moving objects such as flags or parts of plants do not enter the detection range of the sensors.
 - ⇒ Do not make any settings on the control unit when the system is in use.
 - ⇒ Have faults rectified immediately by specialist or personnel qualified to do so.
 - ⇒ Remove objects from the opening area.
 - ⇒ Do not disassemble, put out of operation or manipulate safety devices.
 - ⇒ Do not rush through a closing system.



CAUTION

Risk of bruising and severing of limbs!

- a) If the system moves, careless behaviour can lead to serious injuries to limbs or severance of limbs.
 - ⇒ Do not reach in when parts of the system are moving.
 - ⇒ Keep a distance when parts of the system move.
 - ⇒ Do not bump into or touch the system when it is moving.
 - ⇒ Do not open or remove protective covers during operation.
 - ⇒ Do not permanently remove covers from the system.
 - ⇒ Only carry out inspection, service, maintenance and cleaning when the system is stationary and switched off.



CAUTION

Danger of material damage or injury due to non-functioning safety devices!

- a) If safety devices are not functioning, manipulated or put out of operation, there is a risk of damage to property or injuries that can lead to death.
 - ⇒ Never disable or manipulate safety devices.
 - ⇒ Have inspection, service and maintenance of the safety devices carried out according to local regulations or according to a maintenance contract.



CAUTION

Danger of malfunctions, damage to property or risk of injury if used by unauthorised persons!

- a) If unauthorised persons use the system, there is a risk of malfunction, damage to property or injury to persons.
 - ⇒ Children under 8 years of age may only use the system under supervision.
 - ⇒ Children must not play, clean or maintain the system.
 - ⇒ Persons with limited physical, sensory or mental abilities as well as persons with insufficient knowledge or experience may only use the system under supervision or must have received and understood instructions to do so.



DANGER

Danger to life due to electric current!

- a) In case of contact with live parts, there is an immediate danger to life due to electric shock. Damage to or removal of the insulation or individual components can be life-threatening.
 - ⇒ Before starting work on active parts of electrical systems and equipment, ensure that all poles are voltage free and that this is maintained for the duration of the work.
 - ⇒ Keep moisture away from live parts. This can lead to a short circuit.
 - ⇒ Never bridge fuses or put them out of operation.
 - ⇒ Do not connect the power supply until all work has been completed.
 - ⇒ Have work on the electrical system performed by qualified personnel only.



DANGER

Danger to life due to non-functioning safety devices of the fire protection system!

- a) If safety devices of the fire protection system do not function properly, there is a risk of serious or fatal injuries.
 - ⇒ Never disconnect the fire protection system from the power supply overnight.
 - ⇒ Do not disassemble, put out of operation or manipulate safety devices.
 - ⇒ Do not remove safety instructions on the system.
 - ⇒ Never block, hold open or otherwise prevent fire doors from closing.
 - ⇒ Have inspection, service and maintenance of the fire protection system carried out in accordance with locally applicable regulations or according to a maintenance contract.
 - ⇒ Have the fire protection system checked and maintained according to the state of the art.

1.4 State of technology

This system was developed using state of the art technology and officially recognized technical safety regulations. The system, depending on its options and diameter, comply with the requirements of the Machine Guidelines 2006/42/EG as well as EN 16005 and DIN 18650 (D).

Nevertheless, danger may arise if not used as intended.



IMPORTANT

Installation, commissioning, inspection, maintenance and repair work may only be conducted by qualified, trained and authorized technicians.

After commissioning or repair work, fill in the check list and give it to the customer for safe keeping.

We recommend obtaining a service agreement.

1.5 Personal protective equipment

Personal protective equipment is used to protect persons from adverse effects on health. Personnel must wear personal protective equipment during the various work activities on and with the system.

Personal protective equipment is explained below:



Hearing protection is used to protect the hearing from noise. As a rule of thumb, hearing protection is compulsory from when normal conversation with other people is no longer possible.



The head protection serves to protect against falling and flying parts and materials. It also protects the head from bumping into hard objects.



Protective goggles protect the eyes from flying parts, dust, splinters or splashes.



Protective gloves are designed to protect hands from friction, abrasions, punctures or serious injury and from burning caused by contacting hot surfaces.



Safety shoes protect the feet from crushing, falling parts and slipping on surfaces. The puncture resistance of the shoes ensures, that pointy objects do not penetrate the foot.



The high-visibility vest is used to make the personnel stand out and therefore to be seen. With improved visibility and attention, the high-visibility vest protects personnel in busy work areas from collisions with vehicles.

Depending on the place of work and the working environment, the protective equipment varies and must be adapted accordingly. In addition to protective equipment for specific work, the work site may require other protective equipment (for example a harness).

In hygiene-protected areas, special or additional requirements of personal protective equipment may be required. These requirements must be considered when choosing personal protective equipment. If there is any uncertainty regarding the choice of personal protective equipment, the safety officer must be consulted at the place of work.

1.6 Spare parts and liability

Reliable and trouble free operation of the door is only guaranteed when using parts that were recommended by the manufacturer. The manufacturer declines any liability for damages resulting from unauthorized modifications to the door or the use of parts that are not permitted.

2 General information

2.1 Purpose and use of the instructions

These instructions are an integral part of the system and enable efficient and safe handling of the system. In order to ensure proper functioning, the instructions must be accessible at all times and kept in the immediate area of the system.

Although only the male form has been chosen for reasons of better legibility, the information refers to members of both sexes.

The operator must have read and understood the manual before starting any work. The basic requirement for safe working is to follow the safety instructions and the handling instructions. In addition, the local regulations and safety rules apply.

The manual can be handed over in extracts to instructed personnel who are familiar with the operation of the system.

The illustrations are for basic understanding and may differ from the actual presentation. Specific representations are contained in the drawings.

2.2 Copyright

The copyright of the instructions remain at:

BLASI GmbH

Carl-Benz-Str. 5-15

D – 77972 Mahlberg

It is prohibited to reproduce, distribute or use the manuals for purpose of competition without the written authorization of BLASI GmbH.

Violation of the here stated copyrights will be prosecuted and fined with compensation of damage.

Subject can change without prior notice.

Differences between product and manual are thereby possible.

2.3 Product identification

The nameplate located on the door provides accurate identification of the product.

2.4 Manufacturer BLASI GmbH

BLASI GmbH Automatic Door Systems

Carl-Benz-Str. 5-15

D-77972 Mahlberg

Germany

Telephone: +49 7822-893-0

Fax: +49 7822-893-119

2.5 Target groups



CAUTION

Risk of injury if personnel are insufficiently qualified!

If unqualified personnel work on the system or are in the danger zone of the system, dangers may arise which can cause serious injuries and considerable damage to property.

- a) All work must be carried out by qualified personnel only.
- b) Keep unqualified personnel away from danger areas.

This operating manual is intended for the target groups listed below:

- Operating entity of the system:
the person who is responsible for the technical maintenance of this system
- Operator of the system:
the person who operates the system every day and has been suitably instructed

2 General information

2.6 Definition of terms

Term:	Explanation:
System	<p>The term is also used in these instructions as a synonym for the product. Door operators, revolving doors, sliding doors, etc. are referred to as a system.</p> <p>If information in these instructions refers to a specific type, this is shown accordingly in the text.</p>
User	Users are all persons who use the system.
System operator	The respective owner is referred to as the system operator, regardless of whether they operate the system as the owner or pass it on to third parties.
Authorized representative	The authorized representative takes over certain parts of the manufacturer's obligations with regard to fulfilling the requirements of the Machinery Directive. In particular, the authorized representative may also place the system on the market and/or sign EC declarations of incorporation.
Qualified personnel	<p>Qualified personnel are authorized and appropriately trained to perform the following work:</p> <ul style="list-style-type: none">– Disassembly, Assembly, Commissioning, Operation, Audit, Maintenance, Troubleshooting, Decommissioning <p>The qualified personnel have several years of professional experience in the technical field, e.g. as mechanics or machine fitters.</p> <p>The qualified personnel are aware of the residual risks arising from the installation site and, due to their professional training, knowledge and experience, are able to carry out the work assigned to them and to independently identify and avoid possible danger points.</p>
Manufacturer	The manufacturer is whoever designs and/or builds machinery or incomplete machinery under the scope of the Machinery Directive.
Life phases	All phases of the system's condition and use are referred to as life phases. This applies from the time the system leaves the factory until it is disposed of.
Personnel	All persons who carry out activities on and with the system are referred to as personnel. Personnel can be, for example, the operator, the cleaning staff, or the security staff. The personnel meet the personnel qualifications required by the manufacturer.
Service technician	Experts and specialists or representative authorized by the manufacturer to perform commissioning, maintenance and servicing.

3 Description

3.1 Graphical illustrations

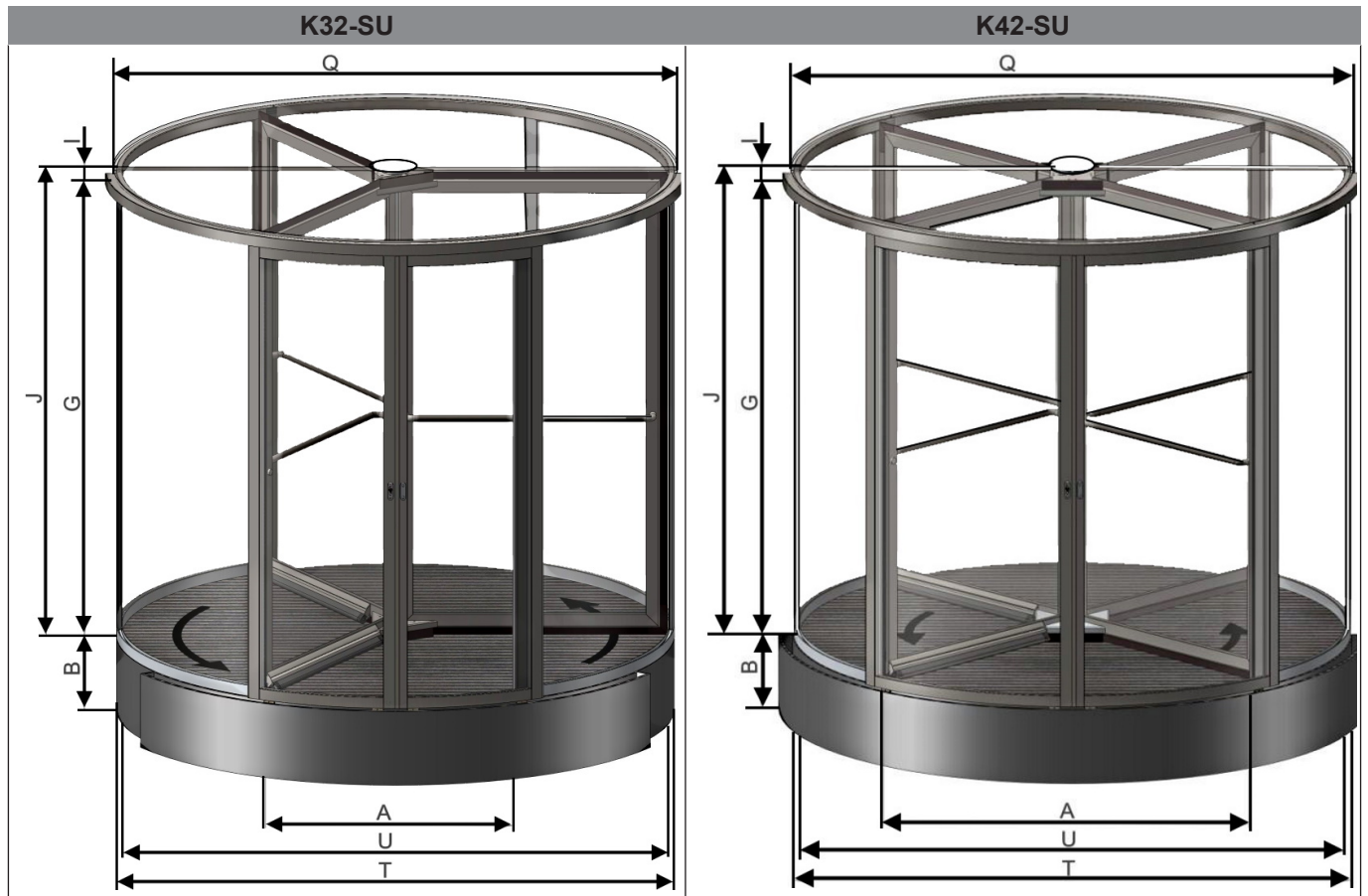

Abbreviation	Description	Abbreviation	Description
A	Passage width	B	Ground ring height
G	Passage height	I	Cladding height
J	Overall height	Q	Overall diameter
T	Outer diameter	U	Inner diameter

3.1.1 Main mechanical components

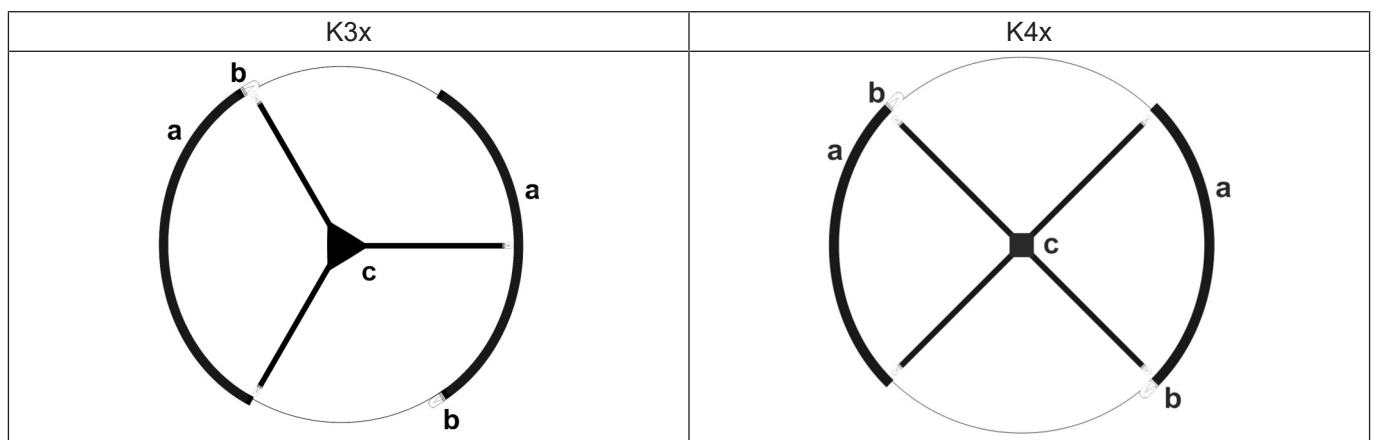

3 Description

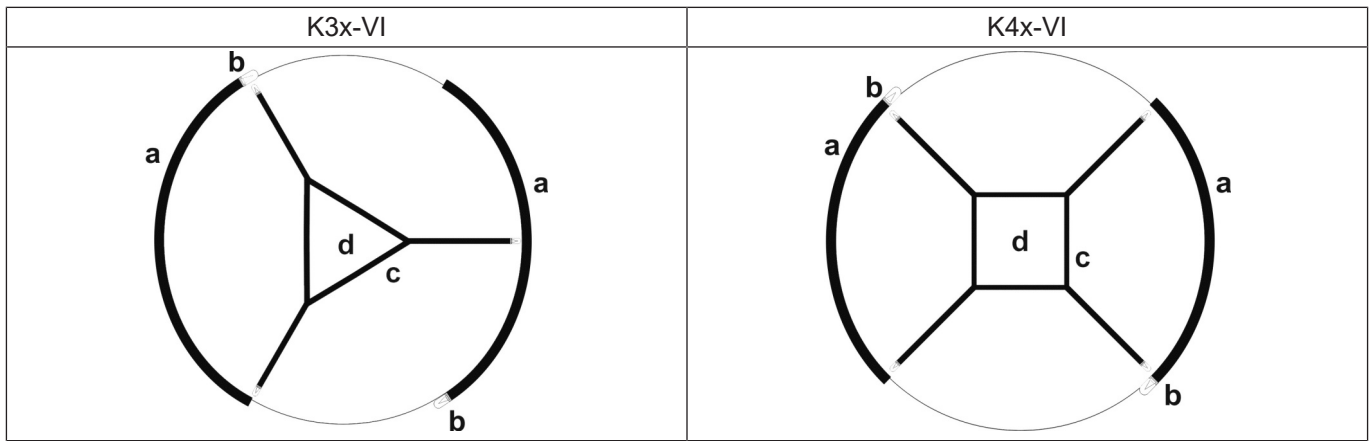

Description	
a	Drum wall Curved, fixed aluminum frame for supporting curved glass or paneling.
b	Drum wall edge Fixed structure made of vertical frame profiling for accommodating control units.
c	Rotation unit turnstile Rotating inner part of the revolving door.
d	Display case Show case in the centre of the rotation unit.

3.2 Description of the door

The door consists of two or three turnstile wings

It has a microprocessor-controlled drive system, which can be used in several operating modes.

The different operating modes can be selected with the corresponding BDE-D-KTA control unit.

A built in error analyzer detects operating errors.

Safety sensors prevent hazardous rotational movement which slows down or stops the turnstile at the right time. The operating state or system error is displayed on the BDE-D-KTA control unit.

3.3 Safety features and control elements K32 / K42

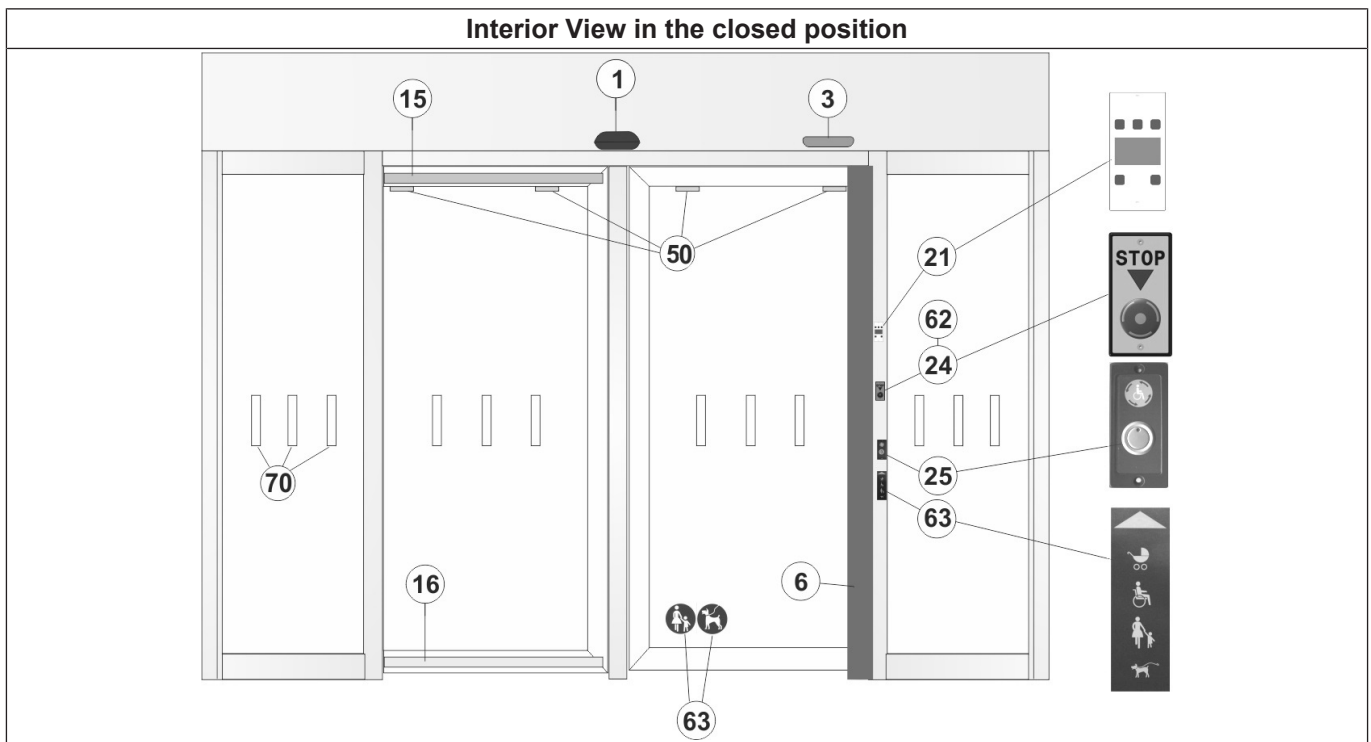

Operating element variations available

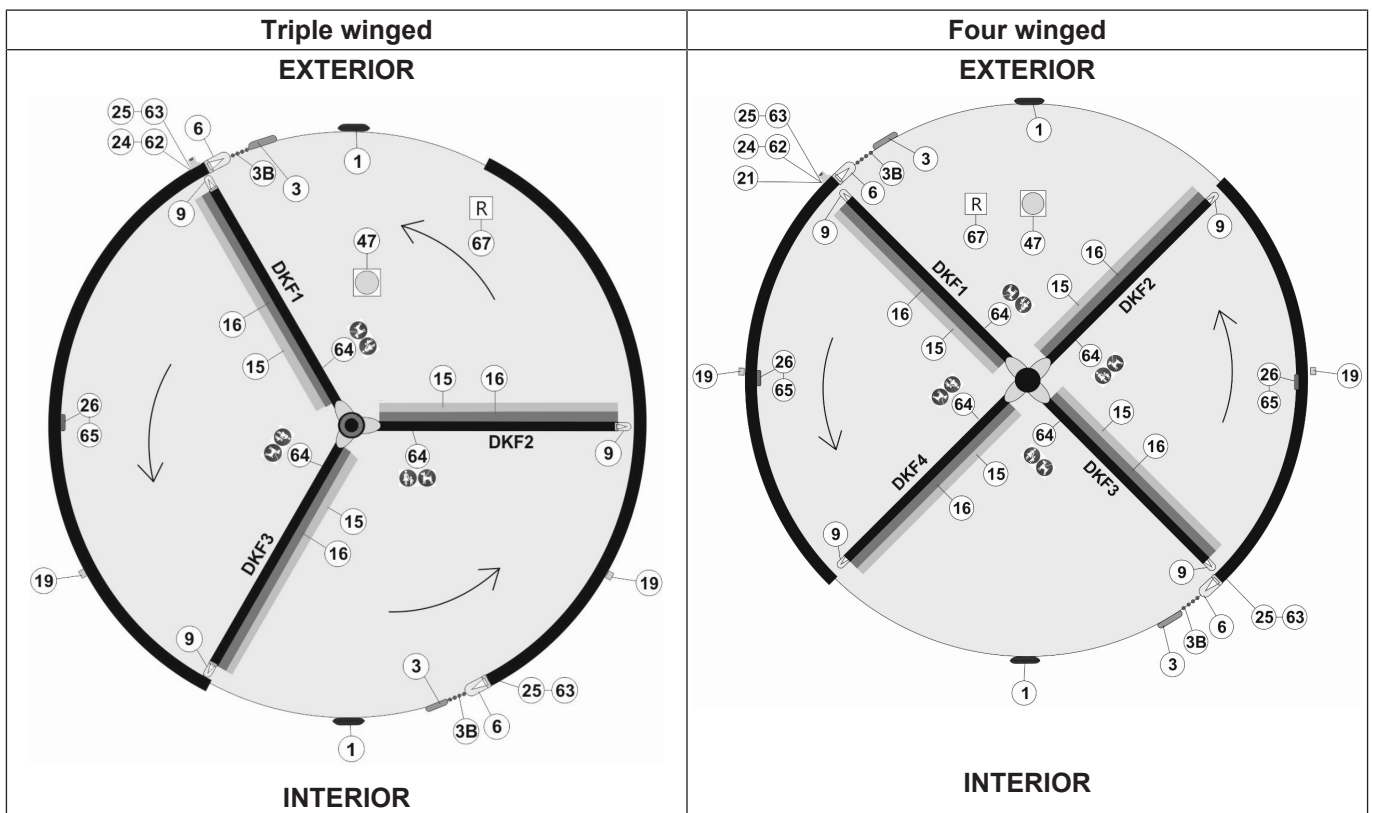
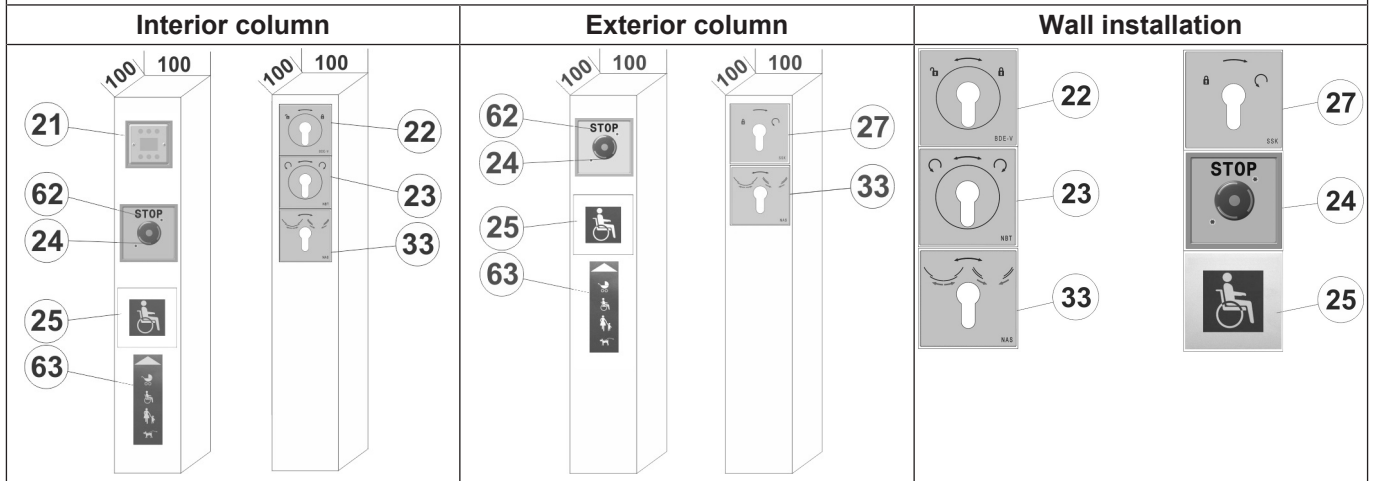

Position of the turnstile wings in the locked position:

Turnstile wing	K32	K42
DKF1 = Turnstile wing 1	0°	0°
DKF2 = Turnstile wing 2	120°	90°
DKF3 = Turnstile wing 3	240°	180°
DKF4 = Turnstile wing 4	—	270°

3.3.1 Legend for safety features and control elements

Pos. No.	Components
1	Motion detector canopy or floor installation (AKI / AKA)
2	Vertical forward sensor radial protective sliding wing (OP-VLS)
3, 3A, 3B	Vertical sensors drum edges (OP-VSS)
4	Horizontal heel protection light barrier SLOW (OP-HSR)

3 Description

5	Horizontal heel protection light barrier STOP (OP-HSR)
6	Vertical safety strips drum edges (SL-TRK)
7	Vertical safety strip radial protective sliding wing (SL-RSF)
8	Vertical safety strip radial fixed wing (SL-VSR)
9	Vertical safety strips turnstile wings (SL-VSR)
10	Radial protective sliding wing (RSF)
11	Power storage (rubber rope)
12	Surveillance contact radial protective sliding wing (UW-RSF)
13	Rotor lock
14	Radial protective sliding wing lock
15, 15A	Sensors turnstile wings (OP-VSR)
16	Horizontal heel protection safety strips (SL-FES)
17	Foot protection sensor radial protective sliding wing
18	Vertical light barriers drum edges
19	Monitoring contact night shield (UW-NAS)
20	Main power switch (UW-HAS)
21	Control unit BDE-D-KTA
22	Key-operated switch BDE-V
23	Key-operated emergency switch
24	Emergency stop switch
25	Disabled person button
26	Start button
27	Key pivot contact
28	Contact mat blocked segment
29	Key-operated switch
30	Sliding door drive STA 20
31	Sliding door control unit BDE-D-STA
32	Traffic light red / green (alternatively in the standing column)
33	Turn key switch night shield
34	Light barriers pivot wing joints
35	Emergency open button
36	Contact mat exit direction
37	Contact mat entrance direction
38	On-site code card reader (1x interior and 1x exterior)
39	Horizontal sensor strip (opening and closing side)

40	Lock mechanism status indicator VRM rotor
41	Door position indicator TPA rotor
42	Lock mechanism status indicator VRM radial protective sliding wing
43	Door position indicator TPA radial protective sliding wing
44	Drive gear box (subfloor)
45	Safety sensors (shearing edge / crushing edge)
46	Electromagnetic lock with bolt contact
47	Turnstile lock
48	“Open position” night shield wing
49	FPC service outlet
50	Lighting
51	Combination sensors
60	Plastic manufacturer's logo
61	System nameplate
62	Sticker STOP
63	Sticker Baby carriage / Wheel chair / Mother + Child / Dog
64	Sticker Mother + Child/ Dog
65	Sticker START
66	Sticker Maximum weight
67	Sticker “Opening service trap”
70	<p>Glass label (example)</p> <p>Labelling the glass surface reduces the danger of collision. Transparent wings or wing surfaces must be clearly visible, for example, by permanent labelling, appropriate markings or use of coloured materials.</p> <p>Stickers, sandblasting, dyeing or etching can be used for labelling. Quantity and design are determined separately.</p>
71	<p>Brush seals</p> <p>The door wing frames of the rotation unit are sealed all around with interchangeable brush strips to prevent drafts.</p>
72	<p>Canopy</p> <p>Encircling canopy panels made of bent aluminum sheets. The entire drive system and controls are located behind the canopy panels. The ceiling panels are part of the turnstile unit and are lined with concentric cut aluminum panels, which can be removed for inspection.</p>
73	External control box
74	Deadman button

3.3.2 BDE-D-KTA control unit

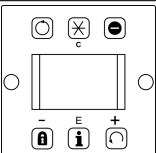
	<p>The electronic BDE-D-KTA control unit is a convenient input and output terminal for operating the door. Clearly arranged buttons enable easy operation of the door modes and navigation of the drive-specific menu structure. The LCD display with backlight supports users with logical symbols and text messages and provides information on the state of the door.</p>
---	--

3 Description

3.3.3 Emergency stop button

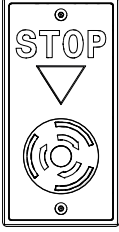
	<p>When the emergency stop button is pushed the rotating turnstile is stopped immediately, the turnstile is released and can be rotated manually.</p> <p>After resetting the emergency stop button, the preset operating mode will continue.</p>
---	--



NOTICE

The turnstile cannot be turned manually on a subfloor door with a geared motor!

3.3.4 Information on motion detectors



NOTICE

Moving objects, i.e. loose poster or plants that move in the detection area can trigger an unintentional startup.

Motion detectors are installed on each access side of the door (see “Safety and operating components legend”).

These motion detectors detect moving persons. If for example, the detection field of a motion detector is entered in the AUTOMATIC operating mode, the turnstile will start to rotate from the start position. If the detection field is entered in the CONTINUOUS operating mode, (slow speed) the turnstile will accelerate from slow speed to walking speed.

3.3.5 Vertical safety sensors drum edge

The danger zones between the rotating turnstile wings and the fixed drum wall edges, on the access sides of the door are secured with vertical safety sensors that radiate to the ground.

These safety sensors are only enabled when the rotating turnstile wing approaches the drum wall edge within approx. 40 degrees (danger zone). When a safety sensor is activated inside the danger zone, the turnstile will either stop immediately or switch to slow speed, depending on how the parameters have been set on the door control. As long as a safety sensor is activated, the stop setting will be held. The slow speed setting remains active until the turnstile reaches the end position. Then the turnstile will accelerate again and resume until another safety sensor is activated. When the safety sensors are no longer activated, the turnstile will accelerate back to the pre-adjusted speed.

3.3.6 Information on safety strips



CAUTION

Risk of destruction Safety edge

- a) Personal injury and damage to property due to malfunctions on the safety edge
 - ⇒ Do not use pointed or sharp-edged objects when working on the safety edge.
 - ⇒ Do not use aggressive cleaning agents such as mineral oils or petrol when working on the safety edge.



NOTICE

On the drum wall edges of the system and on the lower and outer turnstile profiles of the turnstile wings, vertical and horizontal safety bars made of soft rubber are mounted in the direction of rotation. When a safety bar is actuated, the turnstile stops turning immediately. When the safety bar is no longer actuated, the turnstile resumes turning.

4 Options

4.1 Electromagnetic turnstile lock (Fail Secure)



NOTICE

Fail Secure = Monostable locking, locked without current.

The system is equipped with a turnstile lock. In the operating mode LOCKED, the turnstile is automatically locked in the home position and unlocked when another operating mode is selected.

If the power supply fails, the status LOCKED or UNLOCKED is maintained. If the turnstile is locked in the event of a power failure, it can be unlocked by means of a manual unlocking device (bow handle).

Please note the following steps:

Unlocking the turnstile lock	
	<ul style="list-style-type: none"> – Pull the bow handle. – Turn bow handle to the right until it reaches the stop and release.
Reset turnstile lock	
	<ul style="list-style-type: none"> – Turn bow handle to the left. – Release bow handle, the bow handle must retract downwards.

4.2 Turnstile bar-bolt lock

The turnstile can be locked with a bar-bolt lock, integrated in the door frame profile. By rotating the profile cylinder together with the ceiling construction, and/or additionally with a fitted socket integrated in the floor.

4.3 Lock mechanism status indicator and door position indicator

Signal contacts (potential-free NO contacts maximum contact load 24 volt AC/DC/0.3 amps) for indicating the locked state of the turnstile and / or night shield. The position of the night shield wing can also be indicated.

In some countries (VdS) tested signal contacts (potential-free NO contacts, tested according to VdS class C, maximum contact load 24 volt AC/DC/0.3 amps) are required according to the German Property Insurers Association. These are then suitable for use in certified alarm systems.

4.4 BDE-V key switch

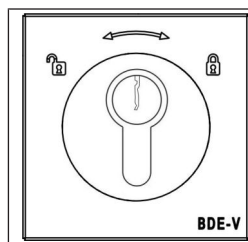

The turnstile can be locked or unlocked with the BDE-V key switch (see Safety and operating components legend).

Only a specific group of people are entitled to lock or unlock and consequently operate the door.



4 Options



CAUTION

Danger of people being trapped inside the turnstile.

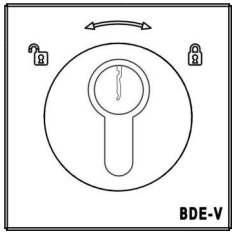
- a) Bruises and contusions through from the turnstile wing.
- ⇒ Visual inspection, check whether people are trapped inside.

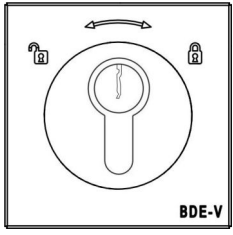
Switch	Operating mode	Display symbol	Function
	Locked		– The operating mode LOCKED is selected by turning the key switch to the right until it stops.
	Varies, according to the preset mode	Varies, according to the preset mode	– The LOCKED operating mode will switch back to the mode preset on the control unit by turning the key switch to the left until it stops.

4.5 Key pivot contact (SSK)

	<p>When the key pivot contact is activated (see “Safety and operating components legend”), the turnstile starts and rotates a minimum of 360° in all operating modes except for MANUAL mode.</p> <p>In the MANUAL mode or when the emergency stop switch is activated, the turnstile can only be rotated manually, with the exception of subfloor system with a geared drive.</p> <p>In the LOCKED mode the turnstile will automatically lock again (if an electric lock is available).</p>
Or – on-site code card reader (CKL)	

4.6 Disabled button

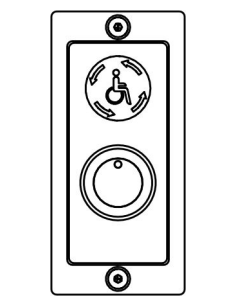
	<p>If the disabled button is pressed in the AUTOMATIC or ONEWAY operating mode, the turnstile will start and rotate 360° plus an additional segment, at slow speed. The motion detectors (if available) will be disabled during this time.</p> <p>In the operating mode CONTINUOUS the turnstile rotates a slow speed. If a disabled button is pressed, the slow speed will be maintained.</p>
	



NOTICE

If the detection area of a motion detector is entered without pressing a disabled button, the turnstile will accelerate to walking speed.

4.7 Start button

**IMPORTANT**

In the LOCKED mode, the start button function is disabled after 10 minutes.

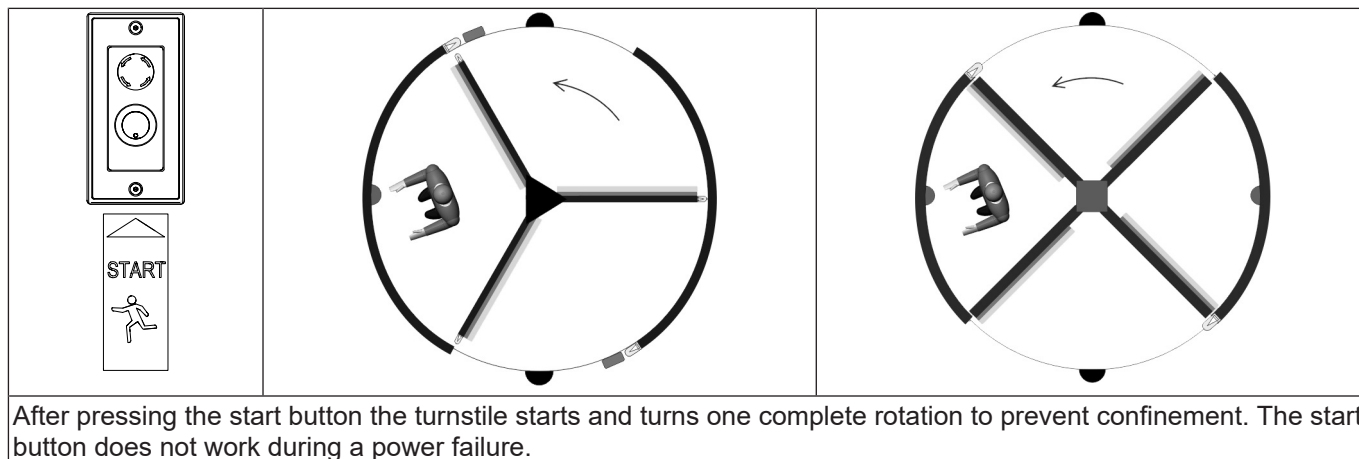

After pressing the start button the turnstile starts and turns one complete rotation to prevent confinement. The start button does not work during a power failure.

4.8 Key emergency operation switch

**CAUTION**

Sensors and safety strips are disabled in the emergency operation mode!

- a) Personal or property damage
 ⇨ In case of emergency press the emergency stop button.

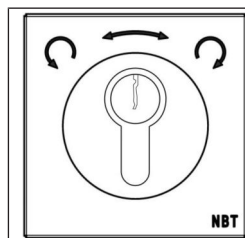

If the operation of the door is prevented, for example by a defective sensor, the turnstile can still be rotated to a desired position in both directions of rotation by an authorized person via the key emergency operation switch (see Safety and operating components legend).

Function: triggers a rotation at reduced speed. Can ignore safety sensors. The emergency stop button remains the overriding function.

Switch	Operating mode Function	
 activated	Emergency operation	<ul style="list-style-type: none"> – As long as the key emergency operation switch is turned and held in the direction of the arrow, the turnstile will rotate at slow speed and will automatically stop in the home position (deadman function). – When the key emergency operation switch is no longer being turned or held, the turnstile stops and remains in its current position.

**NOTICE**

It is necessary for the operator to have visual contact from the location of the key emergency switch to the door!

4 Options

4.9 BDE-Lock key switch

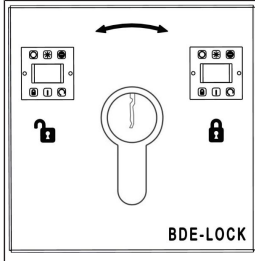

The **BDE-Lock** key switch is used to lock or unlock the BDE-D-KTA control unit for the door. Only a certain people have access to this key switch.

When the **BDE-Lock** key switch is turned to the right (locked), the door will continue in the operating mode that was preset on the BDE-D-KTA (for example, AUTOMATIC).

When the **BDE-Lock** key switch is turned to the right (unlocked), the operating modes can be changed again with the BDE-D-KTA.

4.10 Vertical sensors strips drum walking area

Co-rotating, vertical sensors, radiating to the floor, are mounted on top of the turnstile wings and/or on top of the turnstile centre part. They secure the danger zone from approx. 12-20 cm in front of each turnstile wing to the turnstile centre. When a safety sensor is activated within the danger zone, the turnstile will switch to slow speed or stop depending on parameterization. Slow speed is maintained until a horizontal or vertical electric safety strip on the turnstile is activated. Then the turnstile will stop. When the electric safety strip is no longer activated and no safety sensors are activated, the turnstile will start and accelerate to the preset walking speed.

4.11 Air curtain control

Direct ventilation to the interior via an air duct built into the doorway.

The air curtain is controlled by a potential-free door contact that triggers once the turnstile starts to rotate.

4.12 Foldable turnstile wings and/or foldable drum walls

The system can be equipped with hinged turnstiles and / or, in case of a three-wing system, with hinged drum walls.

If a turnstile leaf and/or a drum wall is manually opened, this condition is signaled to the system control via a monitoring switch. At the same time, the turnstile movement is immediately stopped in all operating modes and the system control is switched off.

To continue the set operating mode, all turnstile leaves and/or the drum walls must be manually re-engaged in their original position.

The turnstile starts automatically and continues the set operating mode.

Folding turnstile leaves are held in position by electrical or mechanical leaf locks.

Folding drum walls are held in position by magnets.

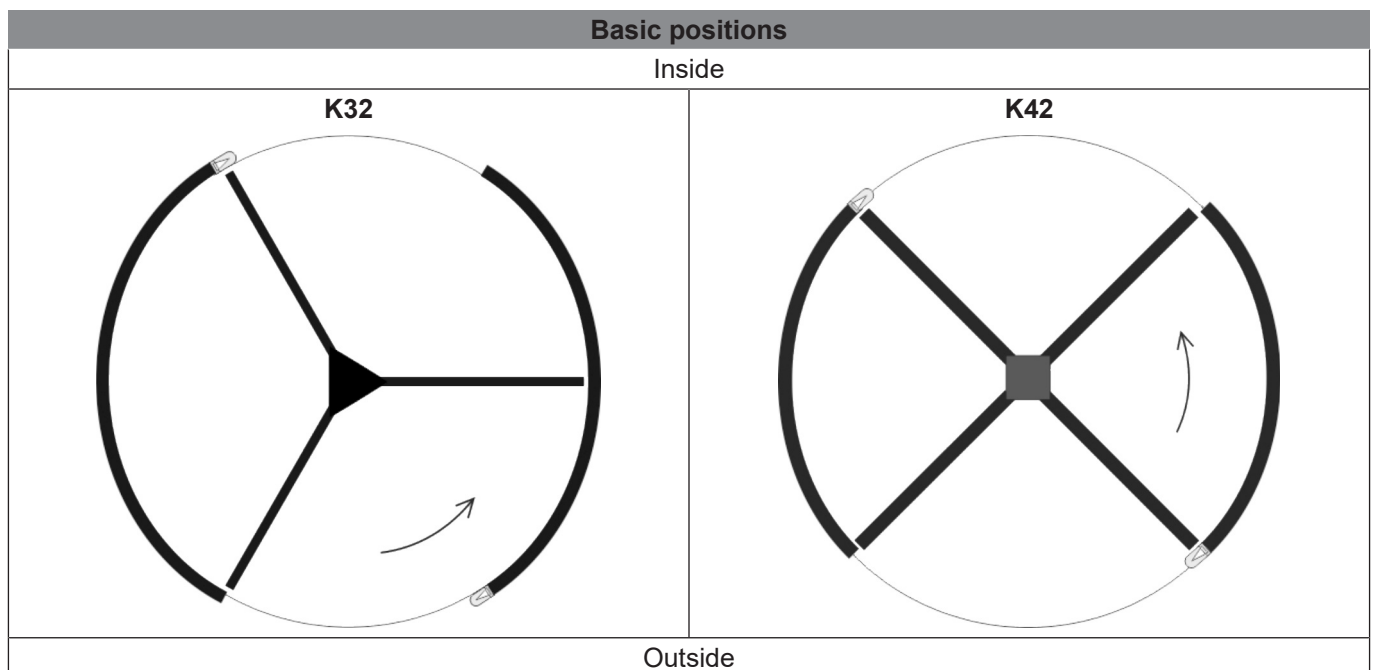

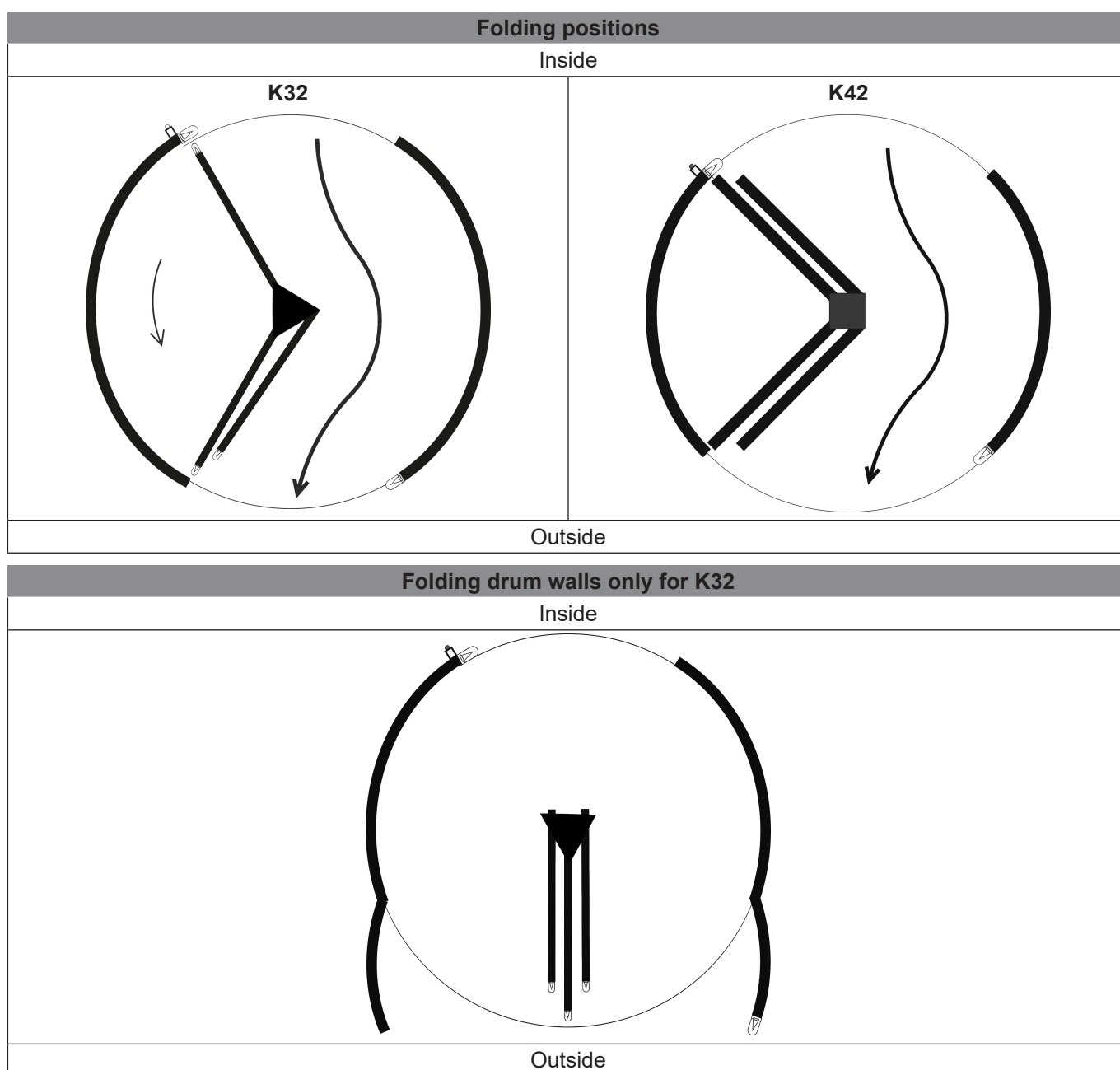

4.13 Light switch

The lighting can be or is connected to an on-site light switch or controlled by the building control system to be switched OFF or ON.

4.14 Lighting control

Depending on the configuration, the lights can either be switched ON or OFF from an external spot or automatically, depending on the operating mode selected, via the door control:

Parameter setting:	Operating mode:	Lighting condition:
Inactive (factory setting)	OFF or AUTOMATIC or CONTINUOUS or MANUAL	Permanently OFF
Only when the turnstile is turning	AUTOMATIC or CONTINUOUS or ONE-WAY	ON
Permanent	LOCKED or AUTOMATIC or CONTINUOUS or ONEWAY or MANUAL	Permanently ON
Permanently ON, except when locked	LOCKED or AUTOMATIC or CONTINUOUS or ONEWAY or MANUAL	ON or OFF

4 Options

4.15 Night shield



NOTICE

The door is equipped with a night shield located on the exterior entrance. If it is manually pushed out of the open position while rotating, the turnstile will immediately stop for safety reasons. For safety reasons, the automatic mode only functions if the night shield is completely open. During a power failure, the status of the night shield remains LOCKED or UNLOCKED.

4.15.1 Manual night shield

Night shield with mechanical bar-bolt lock or hook bolt lock

The night shield can be locked and unlocked with profile cylinder locks integrated in the door frames. If the night shield is in locked position, then it must be unlocked and completely pushed open manually.

Then the operating mode of the door can be selected.

4.15.2 Night shield - deadman



CAUTION

Night shield crushing danger

- a) Fingers or hands getting crushed, sheared or pulled in
 - ⇒ To avoid crushing, the operator must have a clear view of the night shield during the OPENING and CLOSING process.



NOTICE

If the night shield is manually locked (i.e. with a bar lock), then please ensure that the night shield wings are manually unlocked before using the key reversing switch.

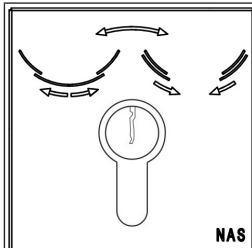

Switch example

It can be operated with the key reversing switch.

Opening process: the night shield is opened by turning the key reversing switch to the right (see arrow direction) and holding the position. If the night shield is locked electrically, then it will simultaneously unlock. The opening process will stop when the key reversing switch is no longer being turned or held. The opening process will resume by turning the key to the right again and holding the position.

Closing process: the night shield is closed by turning the key reversing switch to the left and holding the position. The closing process will stop when the key reversing switch is no longer being turned or held. If the night shield is locked electrically, then it will lock automatically in the locked position.

Collision detection: if a night shield wing hits an obstacle during the opening or closing process, the night shield will stop and remain stopped. The next opening or closing process will start when the key reversing switch is turned and held in position again.

4.15.3 Fully automatic night shield

It is operated with a door open button, or a turn key switch, or an on-site code card reader.



CAUTION

Night shield crushing danger

- a) Fingers or hands getting crushed, sheared or pulled in
 - ⇒ To avoid crushing, the operator must have a clear view of the night shield during the OPENING and CLOSING process.

Fully automatic night shield drive with electric lock:

Place the door in the LOCKED operating mode.

The night shield is closed and electrically locked.

By pressing the door open button, or using the turn key switch or on-site code card reader, the night shield will unlock and open up completely.

Once the night shield is completely opened, the turnstile will start, turn one complete rotation at slow speed and come to a standstill in the home position.

Then the night shield closes again automatically and locks.

In the operating modes AUTOMATIC, CONTINUOUS and MANUAL, the night shield unlocks itself, opens automatically and remains open. If switched to the LOCKED operating mode, the night shield closes again automatically.

Security sensors: if the detection area of the security sensors is entered during the closing process, the night shield will open (reverse) immediately. If no security sensors are activated the night shield will close and lock automatically.

Collision detection: if the night shield wing strikes an obstacle during the closing process, the night shield will stop and open again. The next attempt to close will start from the obstruction area at slow speed.

The night shield will also stop, if its wing strikes an obstacle during the opening process. The next attempt to open will start at slow speed.

5 Specifications

5 Specifications

5.1 Environmental conditions

Temperature range	From -15 to +50° C
Humidity range	Up to 85% rel. humidity, not condensing

5.2 Electric specifications of the door



NOTICE

For underfloor systems, an additional external upstream RCD circuit breaker $I_n = 30\text{mA}$ (FI circuit breaker) must be installed by the customer.

Mains connection:	230 VAC
Frequency:	50-60 Hz
Rated power:	Max. 300 W
Mains fuse:	10A circuit breaker with tripping characteristic C or K
Control voltage:	24 VDC
Motor voltage:	48 VDC
Protection class for underfloor systems:	3

5.3 Electrical specifications power supply

Mains voltage	100-240 VAC, 50/60 Hz
Nominal power	See system nameplate
Fuse	16 A breaker with tripping characteristics C or K
Safety class	1



NOTICE

The power connection must be installed by a licensed electrician. One must be able to turn the power supply off completely via a main switch or residual current circuit breaker.

5.4 Electrical specifications of the door control KST200

Type of control	1x KST200 Master 1x KST200 Slave 1x STM20 (if with night shield) 1x STM20 (For K22 with sliding door) Up to 6x AST200 (Motor control) / Motor
Switching power supply for control voltage	100-240 VAC – 24 VDC / 200 W (short-circuit proof)
Switching power supply for motor voltage	100-240 VAC – 48 VDC / 600 W (short-circuit proof)
Type of motor	DC motors 48 VDC

5.5 Electrical lighting specifications

High-Power LED-Spots	
Mains connection Transformer	100-240 VAC
Frequency	50-60 Hz
Secondary transformer power	120 W
Output per luminaire/illuminant	4.5 W
Protection class / Insulation class	2
Transformer Degree of protection	IP 67

**NOTICE**

The power connection must be installed by a licensed electrician.
The power must be able to be shut off via a main switch or residual current circuit breaker (on-site).











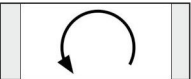

5.6 Sound pressure level

The A-weighted emission sound pressure level of the drive is less than 70 dB. $L_{pA} < 70 \text{ dB (A)}$.

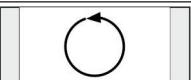
6 Operation

6 Operation

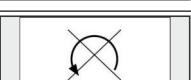

6.1 Operating mode symbols

Operating modes	Control button	Standard display symbol
LOCKED		
UNLOCKED or SSK opening	By SSK opening press the locked button 1 more time	
AUTOMATIC		
CONTINUOUS		
ONEWAY		
MANUAL 2x briefly or 1x long - press (>2s)		
Restart lock After reset press the info button 1x long (>2s)		
Emergency operation button		

6.2 Instructional symbols

If information is required or an error message occurs, the display continues to show the current operating mode (see example 1 + 2). However, the instructional symbol will be also be displayed.

Both instructional symbols could be displayed at the same time (see example 3).

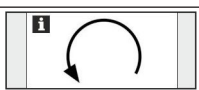
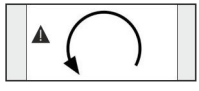
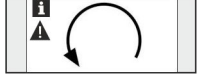
Type	Instructional symbol
Information	
Error	
Example 1: Operating mode with information symbol	
Example 2: Operating mode with error symbol	
Example 3: Operating mode with both instructional symbols	

6.3 Menu display

You can switch to the menu display by briefly pressing the INFO Button  twice (double-click).

The menu display is used to select the defined event groups (information and errors) or the system information to call up the corresponding submenu.
The display is as a list, the currently selected entry is inverted (light text on dark background).

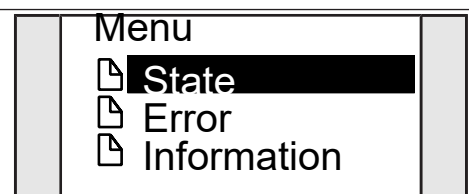

6.4 Status display

The status display shows information with status number and message in plain text. If there is more than one piece of information, the number and the current entry number is also displayed. The next entry is called up by pressing the info key.



6.5 Error display

Current errors are displayed in the error display as a list of the error numbers without plain text display in decimal format. The error number consists of error source (2) and error number (1).

Up to three error codes can be listed per display. If there are more errors, the number of displays and the current display number are also displayed. The next page is called up by pressing the info key.

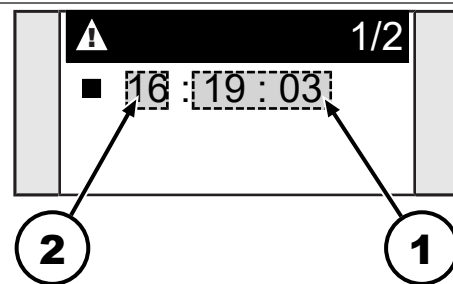

6.6 Operating modes selection

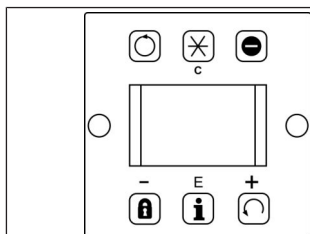

Select the operating mode of the door by pressing the appropriate button on the BDE-D-KTA control unit.

button	operating mode	display icon	function
	Locked		<ul style="list-style-type: none"> – The turnstile rotates to the home position. – The turnstile locks automatically in the home position (if a turnstile lock is available).
	Automatic		<ul style="list-style-type: none"> – The turnstile and the rotation at walking speed are activated by the motion detectors. – If the motion detector is not activated again, the turnstile rotates to the home position and stops.
 press briefly	Continuous rotation		<ul style="list-style-type: none"> – The turnstile rotates continuously at slow speed. It accelerates to walking speed once a person enters the detection range of the motion detectors. – If the motion detector is not activated again, the turnstile rotates to the next home position and then switches back to slow speed. – The turnstile will rotate permanently until a different operating mode is selected.
 approx. 2 sec. long or press 2x briefly	Manual mode		<ul style="list-style-type: none"> – Press the button for approx. 2 sec. or press 2 times consecutively. – The turnstile stops and can be rotated manually in the normal direction (counter clockwise). – The safety features remain enabled. – The maximum allowable rotation speed can not be exceeded (motor brakes).

6 Operation



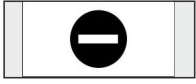

NOTICE

The physical force required for manually pushing the door in the **MANUAL** mode is determined by the size of the turnstile and the friction that occurs. The larger and heavier the turnstile is, the more physical force is required.







 press briefly	One way		<ul style="list-style-type: none"> – The external motion detectors and disabled button are deactivated. – The revolving door is only accessible in one direction (for example, at closing time from inside to outside). – As long as the turnstile is rotating the door is accessible through the entrance.
--	---------	---	--

6.7 Special function selection

Select the special functions by pressing the respective button on the BDE-D-KTA control unit.

button	operating mode	display icon	function
 press again	One turn		<ul style="list-style-type: none"> – By pressing the key, the turnstile unlocks (if turnstile lock is present) and starts a turning movement (360°). – In the home position, the turnstile is locked again.

6.8 Operating lock via the keyboard

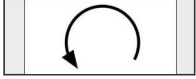
Locking the control unit				
Press key sequence		Display symbol		Description
				<ul style="list-style-type: none"> – The control panel keys are locked. – Unwanted manipulation of the control unit is impaired. – The locked state of BDE-D-KTA control unit is displayed on the screen with a key symbol (bottom left).
Unlocking the control unit				
Press key sequence		Display symbol		Description
				<ul style="list-style-type: none"> – The control panel keys are activated. – Operating modes and special functions can be selected.

7 Servicing and maintenance

7.1 General remarks

According to current legislation, the operator of an automatic door system is responsible for its maintenance and safety.

Accidents or defects can be avoided if the system operator takes good care of the system.

Testing

Type of test	Measure
Visual inspection	Check door leaves, guides, bearings, limiting devices, sensors, and the securing of crushing and shearing points for damage.
Mechanical inspection	Check fastenings for tight fit.
Safety check (exit and escape routes)	Check sensors, safety devices, and monitoring devices for tight fit and damage.
Function testing	Check functioning of switches, operators, controllers, power or energy storage devices, and sensors. Also check the adjustment of the safety devices and the setting of all movement sequences including the end points.

Servicing

Type of servicing	Measure
Adjusting and cleaning	Clean and adjust bearings, sliding points, and power transmission.

For documentation and information purposes, the testing and servicing work as well as the condition of the system are recorded in a test log book. The test log book must be kept for at least one year or until the next testing/servicing.



IMPORTANT

The testing and/or servicing interval according to the manufacturer's specification is at least 1 to 2 times a year.



IMPORTANT

The recommended and planned spare parts and wearing parts can be requested from your service center.

7.2 Monthly inspection work performed by the operator

The monthly tests and inspections of individual components by the operator require little time and serve in particular to prevent accidents caused by improper handling of the system. Depending on the equipment of the plant, we recommend that the following inspection work be carried out on a monthly basis.

Item Nr.:	Test / Control	Procedure	Expected result
1	Function test motion detectors	<ul style="list-style-type: none"> – Select the AUTOMATIC operating mode. – When the turnstile comes to a standstill, enter into the detection area of the motion detector. – Conduct this test from the interior and exterior. 	<ul style="list-style-type: none"> – The turnstile must start to rotate in time.

7 Servicing and maintenance

6, 9, 16	Visual inspection of all safety strips	<ul style="list-style-type: none"> – Select the MANUAL operating mode. – Visually inspect all safety strips. 	<ul style="list-style-type: none"> – The safety strips must not have any mechanical damage and they must be installed correctly and firmly over the entire length.
22 possibly on the ex- terior	Function test BDE-V key switch	<ul style="list-style-type: none"> – Start the turnstile rotating in AUTOMATIC or CONTINUOUS mode. – Turn the key switch to the right to LOCKED. – Turn the key switch to the left to UNLOCKED. 	<ul style="list-style-type: none"> – The turnstile rotates to the locked position and locks. – The turnstile unlocks and goes back to AUTOMATIC mode.
23 possibly on the ex- terior	Function test key emer- gency switch	<ul style="list-style-type: none"> – Start the turnstile rotating in AUTOMATIC or CONTINUOUS mode. – Turn the key emergency switch to the left or right for approx. 5 seconds. 	<ul style="list-style-type: none"> – The turnstile rotates at slow speed in the predefined direction of rotation. – When the key emergency switch is released the turnstile will stop immediately! The operating mode can be changed with the BDE-D-KTA.
24	Function test emergency stop button	<ul style="list-style-type: none"> – Start the turnstile rotating in AUTOMATIC operating mode. – Press the emergency stop button. – Reset the emergency stop button. 	<ul style="list-style-type: none"> – The turnstile must stop immediately. – After resetting the turnstile will start again.
25	Function test disabled button	<ul style="list-style-type: none"> – Start the turnstile rotating in AUTOMATIC or ONEWAY mode. – The turnstile rotates at slow speed in the CONTINUOUS operating mode. – Press the disabled button. – Perform this test from the interior and the exterior of the door. 	<ul style="list-style-type: none"> – The turnstile must reduce speed but continue to rotate at a slow constant speed for at least 360°. – The slow rotational speed is maintained even when a disabled button is pressed.
26	Function test start but- ton	<ul style="list-style-type: none"> – Select LOCKED mode and wait for the turnstile to stop. Remember in which segment the start button is located. – Enter into the particular segment and wait for the turnstile to come to a stop and lock. Then press the start button. 	<ul style="list-style-type: none"> – When the start button is pressed the turnstile starts and turns one complete rotation, stops in the home position and locks again. The person is able to exit the door.



CAUTION

Danger of people being trapped inside the turnstile.

- a) Bruises and contusions through from the turnstile wing.
 ⇒ Visual inspection, check whether people are trapped inside.

	Function test locked mode	<ul style="list-style-type: none"> – Select LOCKED operating mode. Do not enter the door! – Verify whether the turnstile is locked by trying to push it manually. 	<ul style="list-style-type: none"> – The turnstile will lock securely.
--	------------------------------	---	---

27 possibly on the ex- terior	Function test key pivot contact SSK	<ul style="list-style-type: none"> – Select LOCKED mode. – Turn the key pivot contact briefly. – Also perform in AUTOMATIC and CONTINUOUS mode. 	<ul style="list-style-type: none"> – The turnstile will unlock, turn one complete rotation and lock again. – The turnstile will turn one complete rotation.
62, 63, 64, 65	Visual inspection of the instructions and labelling (buttons / switches)	<ul style="list-style-type: none"> – Verify that labels and instructions are present and legible. 	<ul style="list-style-type: none"> – All warnings and instructions must be present, legible and firmly attached.
70	Visual inspection of glass labelling	<ul style="list-style-type: none"> – Verify that all glass labels are present. 	<ul style="list-style-type: none"> – The glass labels must be present and attached firmly at eye level.
	Visual inspection of floor mats	<ul style="list-style-type: none"> – Inspect the floor mats for tripping hazards, unevenness, damages and dirt accumulation. 	<ul style="list-style-type: none"> – The floor mat must be free from tripping hazards, unevenness, damages and dirt accumulation.



CAUTION

Risk of burning, hot surfaces!

- a) Risk of burning hands when replacing components.
 - ⇒ Allow components to cool for at least 5 minutes before replacement and wear safety gloves if necessary.

	Visual inspection of the lighting	<ul style="list-style-type: none"> – Check that the lamp is firmly seated and switch on the lighting. 	<ul style="list-style-type: none"> – Lamps must be correctly mounted and functioning.
--	-----------------------------------	--	--



WARNING

Resetting the folding turnstile wings

- a) Squeezing and retracting the fingers by movements when resetting the hinged turnstile wings
 - ⇒ Direct bystanders out of the danger area.
 - ⇒ Folding turnstile wings should only be held and moved at the outer edge.

	Function test folding wing	<ul style="list-style-type: none"> – Press to check whether the hinged leaves can be opened. – Check by unlocking whether the hinged leaves can be opened. 	<ul style="list-style-type: none"> – Folding wings must be correctly mounted. – It shall be possible to open top-hung wings with and without active emergency stop.
--	----------------------------	--	---

7.3 Cleaning and care



DANGER

Warning: risk of fatal electric shock!

- a) Risk of death by electrocution
 - ⇒ Do not touch the drive system while the main power is connected.
 - ⇒ Do not spray water into the drive system.



NOTICE

Before cleaning, select MANUAL mode and also press the emergency stop button. Rinse cleaned surfaces with a clean, damp cloth.

7 Servicing and maintenance



IMPORTANT

Keep the system clean from dirt, leaves, snow and ice!

- a) If heavily soiled, please contact a professional.
- b) Do not use road salt or gravel in front of the entrance area or within the system.
- c) We recommend that you impregnate the safety strips with water repellent care products.



IMPORTANT

Any other cleaning products, not mentioned here, should not be used!

What	Interval	Cleaning agent
General parts	Weekly	Damp cloth, neutral to low alkaline, wetting agent solution / vinegar diluted with water
Sensors / safety strips	Weekly	Synthetic cleaner
Floor mats	Weekly	Vacuum cleaner / carpet cleaner
Display cases	Weekly	Commercial glass cleaner

8 Malfunctions

8.1 Conduct during malfunctions



IMPORTANT

If malfunctions that endanger the safety of individuals occur, the system must be turned off. It may not be turned back on until the problem has been resolved by a professional and the danger no longer exists.

8.1.1 Troubleshooting options



NOTICE

Some malfunctions can be rectified by the operator themselves (see Tips for troubleshooting). If the tips do not resolve the problem, please contact your local service centre. Before calling, please note the information displayed on the BDE-D-KTA control unit. This information provides the technician with valuable information for troubleshooting.

8.1.2 Tips for troubleshooting

Listed below are malfunctions and their causes with possible solutions that the operator can perform. If the solutions presented are not successful, the operator must disconnect the main power supply and contact the service centre.

Malfunctions	Causes	Solutions
Turnstile is blocked, can not be electrically unlocked	<ul style="list-style-type: none"> – Lock does not open – Lock is jammed in the lock latch – Lock is defective 	<ul style="list-style-type: none"> – Switch to MANUAL operating mode and shake turnstile briefly
Turnstile rotates permanently but very slow	<ul style="list-style-type: none"> – Disabled button is defective – Safety sensors on the top of the turnstile wing is activated or defective 	<ul style="list-style-type: none"> – Check the disabled button and replace if necessary – Check the safety sensor and replace if necessary
Turnstile will not start but can be rotated manually	<ul style="list-style-type: none"> – MANUAL operating mode is activated – Emergency stop button is pressed – Power failure 	<ul style="list-style-type: none"> – Select a different operating mode – Reset emergency stop button – Restore power
When power is restored the turnstile does not start	<ul style="list-style-type: none"> – Restart lock is activated 	<ul style="list-style-type: none"> – Restart with the BDE-D-KTA control unit
Turnstile will not start, is difficult to turn or tries briefly to start	<ul style="list-style-type: none"> – Excessive friction between the brush seals on the turnstile wings with the floor and drum walls – Obstacle in the rotation area – Motor gearbox damage 	<ul style="list-style-type: none"> – Even floor inequalities and remove the dirt collected under the floor mat if necessary – Remove obstacle – Exchange motor

8 Malfunctions

Turnstile will not start	<ul style="list-style-type: none"> – Door control is defective – Safety strip is activated – Person or object has activated a safety sensor – Foreign object is jammed – Safety sensor surface is dirty – Pivot wing is not properly engaged – Night shield is not completely open – Night shield limit switch is defective 	<ul style="list-style-type: none"> – Check safety strips for damages, clean the surface with soapy water – Remove foreign object – Engage pivot wing properly – Open night shield completely
Power failure	<ul style="list-style-type: none"> – Fuse is blown – Fuse is defective – Main switch is off 	<ul style="list-style-type: none"> – Check fuse – Check power supply – Check main switch

8.1.3 Status display and troubleshooting BDE-D-KTA

The following table lists the possible status messages by their status number, together with a detailed description and information on how to correct and reset the error display.

No.	Display text i-record / BDE	Cause and effect	Possible troubleshooting
100	Internal emergency stop (TA-NHTI) activated	<ul style="list-style-type: none"> – EmergencyStop – Immediate stop of the rotation – Unlocking the door 	<ul style="list-style-type: none"> – Reset button (snap in) – Perform reset – If not successful, contact service
	Emergency stop TA-NHTI		
101	Outside emergency stop (TA-NHTA) activated	<ul style="list-style-type: none"> – EmergencyStop – Immediate stop of the rotation – Unlocking the door 	<ul style="list-style-type: none"> – Reset button (snap in) – Perform reset – If not successful, contact service
	Emergency stop TA-NHTA		
102	Radar inside (AKI)	<ul style="list-style-type: none"> – Door rotates permanently in the operating modes AUTOMATIC and ONE WAY 	<ul style="list-style-type: none"> – Perform reset – If not successful, contact service
	AKI active		
103	Radar outside (AKA)	<ul style="list-style-type: none"> – Door rotates permanently in the operating modes AUTOMATIC and ONE WAY 	<ul style="list-style-type: none"> – Perform reset – If not successful, contact service
	AKA active		
104	Inside push-button for disabled persons (TA-BEHI)	<ul style="list-style-type: none"> – Door rotates continuously at reduced speed in the operating modes AUTOMATIC, ONE WAY and CONTINUOUS ROTATION 	<ul style="list-style-type: none"> – Check push button – Perform reset – If not successful, contact service
	BEHI active		
105	Disabled button outside (TA-BEHA)	<ul style="list-style-type: none"> – Door rotates continuously at reduced speed in the operating modes AUTOMATIC, ONE WAY and CONTINUOUS ROTATION 	<ul style="list-style-type: none"> – Check push button – Perform reset – If not successful, contact service
	BEHA active		
106	Key swivel contact (TA-SSK)	<ul style="list-style-type: none"> – Door rotates permanently 	<ul style="list-style-type: none"> – Check / reset switch – Perform reset – If not successful, contact service
	SSK active		

107	Start button 1 Stator (TA-SRT1_S)	– Door rotates permanently	<ul style="list-style-type: none"> – Check push button – Perform reset – If not successful, contact service
	TA-SRT1 Stator active		
108	Start button 2 Stator (TA-SRT2_S)	– Door rotates permanently	<ul style="list-style-type: none"> – Check push button – Perform reset – If not successful, contact service
	TA-SRT2 Stator active		
109	Vertical sensor stator inside (OP-VSSI)	– OptoStop, OptoSlow, depending on the adjusted sensor function stop the rotation or reduce the rotation speed in the active range of the sensor	<ul style="list-style-type: none"> – Remove object from the detection range of the sensor – Check sensor for contamination, clean if possible – Perform reset – If not successful, contact service
	VSSI active		
110	External vertical sensor stator (OP-VSSA)	– OptoStop, OptoSlow, depending on the adjusted sensor function stop the rotation or reduce the rotation speed in the active range of the sensor	<ul style="list-style-type: none"> – Remove object from the detection range of the sensor – Check sensor for contamination, clean if possible – Perform reset – If not successful, contact service
	VSSA active		
111	Vertical sensor rotor blade 1 (OP-VSR1)	– OptoStop, OptoSlow, depending on the sensor function set Stop rotation or reduce rotation speed	<ul style="list-style-type: none"> – Remove object from the detection range of the sensor – Check sensor for contamination, clean if possible – Perform reset – If not successful, contact service
	VSR1 active		
112	Vertical sensor rotor blade 2 (OP-VSR2)	– OptoStop, OptoSlow, depending on the sensor function set Stop rotation or reduce rotation speed	<ul style="list-style-type: none"> – Remove object from the detection range of the sensor – Check sensor for contamination, clean if possible – Perform reset – If not successful, contact service
	VSR2 active		
113	Vertical sensor rotor blade 3 (OP-VSR3)	– OptoStop, OptoSlow, depending on the sensor function set Stop rotation or reduce rotation speed	<ul style="list-style-type: none"> – Remove object from the detection range of the sensor – Check sensor for contamination, clean if possible – Perform reset – If not successful, contact service
	VSR3 active		
114	Vertical sensor rotor blade 4 (OP-VSR4)	– OptoStop, OptoSlow, depending on the sensor function set Stop rotation or reduce rotation speed	<ul style="list-style-type: none"> – Remove object from the detection range of the sensor – Check sensor for contamination, clean if possible – Perform reset – If not successful, contact service
	VSR4 active		
115	Safety edge inside drum edge (SL-TRKI)	– SafetyStop, Immediate stop of the rotation	<ul style="list-style-type: none"> – Remove object from safety edge, possibly dirt on the floor, under a heel guard – Perform reset – If not successful, contact service
	SL-TRKI active		

8 Malfunctions

116	Safety edge outside drum edge (SL-TRKA)	– SafetyStop, Immediate stop of the rotation	<ul style="list-style-type: none"> – Remove object from safety edge, possibly dirt on the floor, under a heel guard – Perform reset – If not successful, contact service
	SL-TRKA active		
117	Horizontal safety bar rotor blad 1 (SL-FES1)	– SafetyStop, Immediate stop of the rotation	<ul style="list-style-type: none"> – Remove object from safety edge, possibly dirt on the floor, under a heel guard – Perform reset – If not successful, contact service
	SL-FES1 active		
118	Vertical safety bar rotor blade 1 (SL-VSR1)	– SafetyStop, Immediate stop of the rotation	<ul style="list-style-type: none"> – Remove object from safety edge, possibly dirt on the floor, under a heel guard – Perform reset – If not successful, contact service
	SL-VSR1 active		
119	Horizontal safety bar rotor blad 2 (SL-FES2)	– SafetyStop, Immediate stop of the rotation	<ul style="list-style-type: none"> – Remove object from safety edge, possibly dirt on the floor, under a heel guard – Perform reset – If not successful, contact service
	SL-FES2 active		
120	Vertical safety bar rotor blade 2 (SL-VSR2)	– SafetyStop, Immediate stop of the rotation	<ul style="list-style-type: none"> – Remove object from safety edge, possibly dirt on the floor, under a heel guard – Perform reset – If not successful, contact service
	SL-VSR2 active		
121	Horizontal safety bar rotor blad 3 (SL-FES3)	– SafetyStop, Immediate stop of the rotation	<ul style="list-style-type: none"> – Remove object from safety edge, possibly dirt on the floor, under a heel guard – Perform reset – If not successful, contact service
	SL-FES3 active		
122	Vertical safety bar rotor blade 3 (SL-VSR3)	– SafetyStop, Immediate stop of the rotation	<ul style="list-style-type: none"> – Remove object from safety edge, possibly dirt on the floor, under a heel guard – Perform reset – If not successful, contact service
	SL-VSR3 active		
123	Horizontal safety bar rotor blad 4 (SL-FES4)	– SafetyStop, Immediate stop of the rotation	<ul style="list-style-type: none"> – Remove object from safety edge, possibly dirt on the floor, under a heel guard – Perform reset – If not successful, contact service
	SL-FES4 active		
124	Vertical safety bar rotor blade 4 (SL-VSR4)	– SafetyStop, Immediate stop of the rotation	<ul style="list-style-type: none"> – Remove object from safety edge, possibly dirt on the floor, under a heel guard – Perform reset – If not successful, contact service
	SL-VSR4 active		
125	Fire alarm contact (BMZ)	– Immediate stop of the rotation	<ul style="list-style-type: none"> – Check / replace onsite switching contact – Perform reset – If not successful, contact service
	Fire alarm	– Release of the escape route via HST200	
126	Night shutter not open or drum wall breakout not closed (UW-POS1_S)	– Immediate stop of the rotation	<ul style="list-style-type: none"> – Fully open the night shield – Close / reset drum wall breakout completely – Reset pivot wings – Perform reset
	UW-POS1 stator active		

127	Night shutter not open or drum wall breakout not closed (UW-POS2_S)	– Immediate stop of the rotation	<ul style="list-style-type: none"> – Fully open the night shield – Close / reset drum wall breakout completely – Reset pivot wings – Perform reset
	UW-POS2 stator active		
128	Pendulum wing 1 deflected (UW-POS1_R)	– Immediate stop of the rotation	<ul style="list-style-type: none"> – Fully open the night shield – Close / reset drum wall breakout completely – Reset pivot wings – Perform reset
	UW-POS1 rotor active		
129	Pendulum wing 2 deflected (UW-POS2_R)	– Immediate stop of the rotation	<ul style="list-style-type: none"> – Fully open the night shield – Close / reset drum wall breakout completely – Reset pivot wings – Perform reset
	UW-POS2 rotor active		
130	Commissioning required	– Immediate stop of the rotation	<ul style="list-style-type: none"> – Perform reset – If not successful, contact service
	Learning cycle required		
131	Self-test is executed	– Stop the rotation	<ul style="list-style-type: none"> – Wait until self-test is finished (approx. 5 sec.) – Perform reset – If not successful, contact service
	Self-test active		
132	Escape route, turnstile wing released	– Immediate stop of the rotation	<ul style="list-style-type: none"> – See triggering states – Reset the turnstile wings – Perform reset – If not successful, contact service
	Breakout wing enabled	– Release of the escape route via HST200	
133	Flow sensor rotor blade 1 (OP-VLS1)	– OptoStop, OptoSlow, depending on the sensor function set Stop rotation or reduce rotation speed	<ul style="list-style-type: none"> – Remove object from the detection range of the sensor – Check sensor for contamination, clean if possible – Perform reset – If not successful, contact service
	OP-VLS1 active		
134	Flow sensor rotor blade 2 (OP-VLS2)	– OptoStop, OptoSlow, depending on the sensor function set Stop rotation or reduce rotation speed	<ul style="list-style-type: none"> – Remove object from the detection range of the sensor – Check sensor for contamination, clean if possible – Perform reset – If not successful, contact service
	OP-VLS2 active		
135	Start button 1 Rotor (TA-SRT1_R)	– Door rotates permanently	<ul style="list-style-type: none"> – Check push button – Perform reset
	TA-SRT1 rotor active		
136	Start button 2 Rotor (TA-SRT2_R)	– Door rotates permanently	<ul style="list-style-type: none"> – Check push button – Perform reset
	TA-SRT2 rotor active		
137	Internal stator safety bar 2 (SL-SI2)	– SafetyStop, Immediate stop of the rotation	<ul style="list-style-type: none"> – Perform reset – If not successful, contact service
	SL-SI2 active		

8 Malfunctions

138	Safety bar stator inside 3 (SL-SI3)	– SafetyStop, Immediate stop of the rotation	– Perform reset – If not successful, contact service
	SL-SI3 active		
139	Safety bar stator inside 4 (SL-SI4)	– SafetyStop, Immediate stop of the rotation	– Perform reset – If not successful, contact service
	SL-SI4 active		
140	Outer stator safety bar 2 (SL-SA2)	– SafetyStop, Immediate stop of the rotation	– Perform reset – If not successful, contact service
	SL-SO2 active		
141	Outer stator safety bar 3 (SL-SA3)	– SafetyStop, Immediate stop of the rotation	– Perform reset – If not successful, contact service
	SL-SO3 active		
142	Outer stator safety bar 4 (SL-SA4)	– SafetyStop, Immediate stop of the rotation	– Perform reset – If not successful, contact service
	SL-SO4 active		
143	Sliding door not closed	– Immediate stop of the rotation	– Wait until sliding door is closed – Move out of the detection field of the sliding door protection – Perform reset – If not successful, contact service
	Sliding door open		
144	Test error vertical sensor stator inside (OP-VSSI)	– ErrorStop, Immediate stop of the rotation	– Perform reset – If not successful, contact service
	OP-VSSI test error		
145	Test error vertical sensor external stator (OP-VSSA)	– ErrorStop, Immediate stop of the rotation	– Perform reset – If not successful, contact service
	OP-VSSA test error		
146	Test error vertical sensor rotor blade 1 (OP-VSR1)	– ErrorStop, Immediate stop of the rotation	– Perform reset – If not successful, contact service
	OP-VSR1 test error		
147	Test error vertical sensor rotor blade 2 (OP-VSR2)	– ErrorStop, Immediate stop of the rotation	– Perform reset – If not successful, contact service
	OP-VSR2 test error		
148	Test error vertical sensor rotor blade 3 (OP-VSR3)	– ErrorStop, Immediate stop of the rotation	– Perform reset – If not successful, contact service
	OP-VSR3 test error		
149	Test error vertical sensor rotor blade 4 (OP-VSR4)	– ErrorStop, Immediate stop of the rotation	– Perform reset – If not successful, contact service
	OP-VSR4 test error		
150	Test error Horizontal light barrier Rotor blade 1 (OP-HSR1)	– ErrorStop, Immediate stop of the rotation	– Perform reset – If not successful, contact service
	OP-HSR1 test error		

151	Test error Horizontal light barrier Rotor blade 2 (OP-HSR2)	– ErrorStop, Immediate stop of the rotation	– Perform reset – If not successful, contact service
	OP-HSR2 test error		
152	Test error flow sensor rotor blade 1 (OP-VLS1)	– ErrorStop, Immediate stop of the rotation	– Perform reset – If not successful, contact service
	OP-VLS1 test error		
153	Test error flow sensor rotor blade 2 (OP-VLS2)	– ErrorStop, Immediate stop of the rotation	– Perform reset – If not successful, contact service
	OP-VLS2 test error		
154	Horizontal light barrier rotor blade 1 (OP-HSR1)	– OptoStop, Immediate stop of the rotation	– Remove object from the detection range of the sensor – Check sensor for contamination, clean if possible – Perform reset – If not successful, contact service
	OP-HSR1 active		
155	Horizontal light barrier rotor blade 2 (OP-HSR2)	– OptoStop, Immediate stop of the rotation	– Remove object from the detection range of the sensor – Check sensor for contamination, clean if possible – Perform reset – If not successful, contact service
	OP-HSR2 active		
156	Stormlock (AuxIn)	– Immediate stop of the rotation – Release of the Stormlock interlocks	– Check / reset switch – Perform reset – If not successful, contact service
	AUX-IN Stormlock active		
157	Emergency open (AuxIn)	– Immediate stop of the rotation – Release of the escape route via HST200	– Check / reset switch – Perform reset – If not successful, contact service
	AUX-IN Emerg. Exit active		
158	Vertical sensor STOP rotor blade 1 (OP-VSR12)	– OptoStop, Immediate stop of the rotation	– Remove object from the detection range of the sensor – Check sensor for contamination, clean if possible – Perform reset – If not successful, contact service
	VSR1_STOP active		
159	Vertical sensor STOP rotor blade 2 (OP-VSR22)	– OptoStop, Immediate stop of the rotation	– Remove object from the detection range of the sensor – Check sensor for contamination, clean if possible – Perform reset – If not successful, contact service
	VSR2_STOP active		
160	Vertical sensor STOP rotor blade 3 (OP-VSR32)	– OptoStop, Immediate stop of the rotation	– Remove object from the detection range of the sensor – Check sensor for contamination, clean if possible – Perform reset – If not successful, contact service
	VSR3_STOP active		

8 Malfunctions

161	Vertical sensor STOP rotor blade 4 (OP-VSR42)	– OptoStop, Immediate stop of the rotation	<ul style="list-style-type: none"> – Remove object from the detection range of the sensor – Check sensor for contamination, clean if possible – Perform reset – If not successful, contact service
	VSR4_STOP active		
162	Test error vertical sensor STOP rotor blade 1 (OP-VSR12)	– ErrorStop, Immediate stop of the rotation	<ul style="list-style-type: none"> – Perform reset – If not successful, contact service
	OP-VSR1_STOP test error		
163	Test error vertical sensor STOP rotor blade 2 (OP-VSR22)	– ErrorStop, Immediate stop of the rotation	<ul style="list-style-type: none"> – Perform reset – If not successful, contact service
	OP-VSR2_STOP test error		
164	Test error vertical sensor STOP rotor blade 3 (OP-VSR32)	– ErrorStop, Immediate stop of the rotation	<ul style="list-style-type: none"> – Perform reset – If not successful, contact service
	OP-VSR3_STOP test error		
165	Test error vertical sensor STOP rotor blade 4 (OP-VSR42)	– ErrorStop, Immediate stop of the rotation	<ul style="list-style-type: none"> – Perform reset – If not successful, contact service
	OP-VSR4_STOP test error		
166	Horizontal safety bar rotor blade backwards 1 (SL-FES1.2)	– SafetyStop, Immediate stop of the rotation	<ul style="list-style-type: none"> – Remove object from safety edge, possibly dirt on the floor, under a heel guard – Perform reset – If not successful, contact service
	SL-FES12 active		
167	Vertical safety bar rotor blade backwards 1 (SL-VSR1.2)	– SafetyStop, Immediate stop of the rotation	<ul style="list-style-type: none"> – Remove object from safety edge, possibly dirt on the floor, under a heel guard – Perform reset – If not successful, contact service
	SL-VSR12 active		
168	Horizontal safety bar rotor blade backwards 2 (SL-FES2.2)	– SafetyStop, Immediate stop of the rotation	<ul style="list-style-type: none"> – Remove object from safety edge, possibly dirt on the floor, under a heel guard – Perform reset – If not successful, contact service
	SL-FES22 active		
169	Vertical safety bar rotor blade backwards 2 (SL-VSR2.2)	– SafetyStop, Immediate stop of the rotation	<ul style="list-style-type: none"> – Remove object from safety edge, possibly dirt on the floor, under a heel guard – Perform reset – If not successful, contact service
	SL-VSR22 active		
170	Horizontal safety bar rotor blade backwards 3 (SL-FES3.2)	– SafetyStop, Immediate stop of the rotation	<ul style="list-style-type: none"> – Remove object from safety edge, possibly dirt on the floor, under a heel guard – Perform reset – If not successful, contact service
	SL-FES32 active		

171	Vertical safety bar rotor blade backwards 3 (SL-VSR3.2)	– SafetyStop, Immediate stop of the rotation	<ul style="list-style-type: none"> – Remove object from safety edge, possibly dirt on the floor, under a heel guard – Perform reset – If not successful, contact service
	SL-VSR32 active		
172	Horizontal safety bar rotor blade backwards 4 (SL-FES4.2)	– SafetyStop, Immediate stop of the rotation	<ul style="list-style-type: none"> – Remove object from safety edge, possibly dirt on the floor, under a heel guard – Perform reset – If not successful, contact service
	SL-FES42 active		
173	Vertical safety bar rotor blade backwards 4 (SL-VSR4.2)	– SafetyStop, Immediate stop of the rotation	<ul style="list-style-type: none"> – Remove object from safety edge, possibly dirt on the floor, under a heel guard – Perform reset – If not successful, contact service
	SL-VSR42 active		

8.1.4 Restarting the door control



NOTICE

In certain cases, the malfunction can be eliminated by performing a restart on the door control.

Observe the following procedure description and press the corresponding keys.



CAUTION

Danger of knocking

- a) Injuries due to dangerous movements in the event of malfunctions or failure of safety devices are possible.
- ⇒ Make sure that nobody obstructs the turnstile and that no person approaches the system that could cause the turnstile to rotate!

Procedure	Press key	BDE-D-KTA display	Function			
Keep the key pressed until the display appears.	<p>E</p>	<table border="1"> <tr><td>No</td></tr> <tr><td>Reset control?</td></tr> <tr><td>Yes</td></tr> </table>	No	Reset control?	Yes	Depending on the mode selected.
No						
Reset control?						
Yes						
Press the key briefly, if no restart (No) is to be performed.	<p>C</p>	Previously set operating mode.	No restart will be performed. The door will continue in the preset operating mode.			
Press key briefly, if a restart (Yes) should be performed.	<p>E</p>		Reset control is activated. Turnstile remains at a standstill. Once complete, the restart lock will be activated.			
Restart lock is activated.			Turnstile remains at a standstill.			
Remove the restart lock: Select a desired operating mode.	Press the key for the desired operating mode briefly.	The symbol for the operating mode selected will be displayed.	The turnstile will start a synchronizing run and rotate 360° at slow speed until it reaches the home position.			



NOTICE

If after restarting the door control an error is still displayed on the control unit, then please contact your service centre and state the error message displayed on the control unit.

8.2 Function during a power failure



CAUTION

Danger of people being trapped inside the turnstile.

- a) Bruises and contusions through from the turnstile wing.
 - ⇒ Visual inspection, check whether people are trapped inside.

In the event of a power failure, the rotation is stopped immediately and the turnstile is then freely rotatable.

The key emergency operation button or start button are without function.



NOTICE

An emergency operation is only possible for a certain bridge period with an external (on-site) or integrated UPS (Uninterruptible Power Supply).

If the system is equipped with a bistable electric turnstile lock, the turnstile remains locked in the basic position in the operating mode LOCKED.

If a monostable closed lock is installed, the system is locked from any operating mode.

9 Taking out of service and disposal

9.1 Decommissioning

When shutting down or taking out of service, the system is disconnected from the mains supply and any existing battery is unplugged.



NOTICE

After each temporary shutdown a new commissioning must be carried out.

9.2 Dismantling and disposal



IMPORTANT

All machine parts must be sorted by type of material and disposed of according to local regulations and guidelines.



NOTICE

The door systems can be completely disassembled in reverse order.

The automatic door mainly consists of the following materials:

Aluminum:

- Linking profiles
- Gearbox, Drive panel
- Door wing profiles and side profiles
- Various profiles and small parts

Steel / iron parts:

- Stainless steel casing, Floor panel, Box recess for floor installation
- Optional spacer or reinforcement profiles
- Gear components, springs
- Various small parts like fittings, covers, linking parts, etc.

Glass:

- Door wings and side panels

Various electronic and electromechanical components:

- Sensors, control and operator components
- Lead batteries and nickel-cadmium rechargeable batteries

Various plastics:

- Rollers
- Cable clips, coupling and linking parts
- Sealing profiles
- Casing of electromechanical components and sensors



Your global partner for entrance solutions